

Chapter 9 Ponds

Definition:

An open body of water that has either occurred naturally or is man-made.

Purpose:

- To promote particle sedimentation, adsorption of nutrients by phytoplankton and ultra violet disinfection.
- They can be used as storages for reuse schemes and urban landform features for recreation as well as wildlife habitat.

Implementation considerations:

- In areas where wetlands are not feasible (e.g. very steep terrain), ponds can be used for a similar purpose of water quality treatment. In these cases, ponds should be designed to settle fine particles and promote submerged macrophyte growth.
- Fringing vegetation, while Aesthetically pleasing, contributes little to improving water quality. Nevertheless, it is necessary to reduce bank erosion.
- Ponds still require pretreatment such as a sediment basins that need maintaining more regularly than the main open waterbody.
- Ponds are well suited to steep confined valleys where storage volumes can be maximised.
- Some limitations for ponds can be site specific for example, proximity to airports, as large numbers of flocking birds can cause a disturbance to nearby air traffic.
- They also require regular inspection and maintenance to ensure that their Aesthetic value is not diminished.



Ponds are popular landscape features in urban areas

9.1	Preface.....	9—3
9.2	Introduction	9—3
9.3	Verifying size for treatment	9—4
9.4	Design procedure for ponds and lakes	9—4
9.5	Checking tools	9—19
9.6	Maintenance requirements.....	9—24
9.7	Worked example.....	9—26
9.8	References	9—41

9.1 Preface

Several sections of this chapter (specifically those in relation to algal growth) make reference to data and studies for sites in Victoria. These sections have not been altered specifically for Tasmania as the theory behind them is applicable to all areas or is derived from studies carried out in Victoria.

9.2 Introduction

Ponds and lakes are artificial bodies of open water usually formed by a simple dam wall with a weir outlet structure or created by excavating below natural surface levels. The depth of water in these waterbodies are typically greater than 1.5 m and there is usually a small range of water level fluctuation although newer systems may have riser style outlets allowing for extended detention and longer temporary storage of inflows. Aquatic vegetation has an important function for water quality management in ponds and lakes. Emergent macrophytes are normally restricted to the margins because of water depth, although submerged plants may occur in the open water zone. The submergent plants will enhance treatment of stormwater inflow and prevent ingress of weed species. Ponds are seldom used as “stand-alone” stormwater treatment measures and are often combined with constructed wetlands as a treatment forebay to the open waterbody. In many cases, these systems ultimately become the ornamental waterbody that require water quality protection.

Ponds and lakes often form part of a flood retarding system and design requirements are generally associated with hydraulic structures for flow conveyance and flood attenuation. These are not covered in this document and only design elements associated with the water quality function of the system is presented.

There have been cases where water quality problems in ornamental ponds and lakes are caused by poor inflow water quality, especially high organic load, infrequent waterbody “turnover” and inadequate mixing. Detailed modelling may be necessary to track the fate of nutrients and consequential algal growth in the waterbody during periods of low inflow (and thus long detention period). As a general rule, it is recommended that the turnover period for lakes between 20 and 50 days (depending on water temperatures) at least 80% of the time (see Appendix D for more information).

If these turnover times can not be met, it may be necessary to introduce a lake management plan to reduce the risk of algal blooms during the dry season.

This design procedure outlines design elements for large waterbodies associated with the design of a constructed lake, an associated wetland forebay (or inlet zone) and water re-circulation scheme (if required) to maintain water quality in the pond. Further investigations need to be undertaken to finalise the design from that presented in the Worked Example to address issue such as the embankment stability and detailed design of structural elements. These are discussed in the worked example.

9.3 Verifying size for treatment

The curves shown in Figure 9.1 describe the pollutant removal performance expected for constructed pond and lake systems in Hobart (reference site) for suspended solids, total phosphorus and total nitrogen. The curves were derived assuming the systems receive direct runoff (ie. no other WSUD elements upstream) and have the following characteristics:

- ▶ The mean depth is 2.0 m
- ▶ Outflow from the system is via an overflow weir.

These curves can be used, together with the adjustment factors derived from the hydrologic regionalisation procedure discussed in Chapter 2, to check the expected performance of the wetland system for removal of TSS, TP and TN.

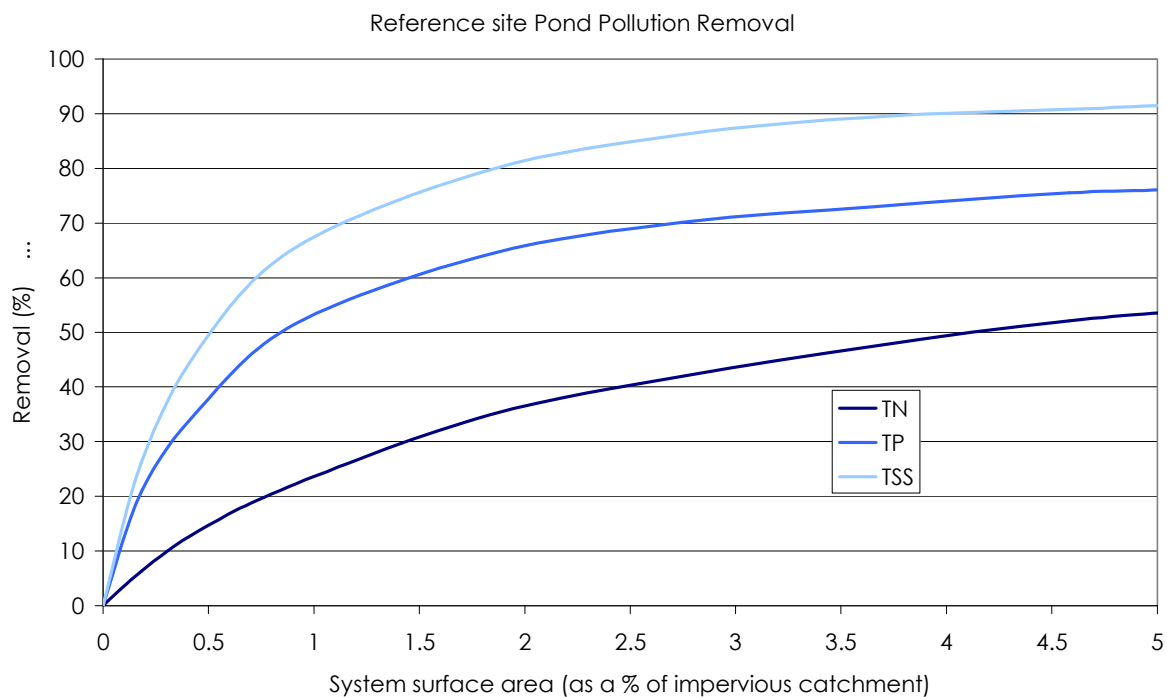

Figure 9.1. TSS, TP and TN removal in pond systems

9.4 Design procedure for ponds and lakes

Design considerations include the following:

1. Computations to ensure that the pond volume is not excessively large or too small in comparison to the hydrology of the catchment.
2. Configuring the layout of the pond and inlet zone such that the system *hydraulic efficiency* can be optimised, including a transition structure between the inlet zone and the open waterbody
3. Design of hydraulic structures

- a. inlet structure to provide for energy dissipation of inflows up to the 100 year ARI peak discharge
- b. Design of the pond outlet structure for the pond
4. Landscape design
 - a. Edge treatment
 - b. Recommended plant species and planting density
5. Maintenance provisions

The figure below summarises the pond/lake design elements. The following sections detail the design steps required for constructed stormwater wetland systems.

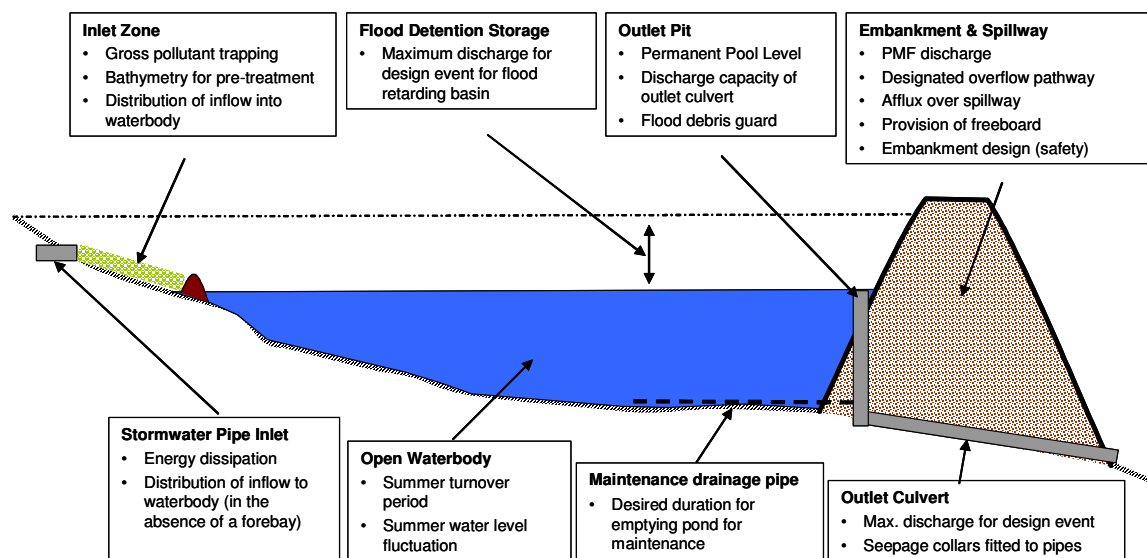

Figure 9.2. Pond/Lake design elements and design considerations

9.4.1 Hydrology

The hydrologic operation of a pond or lake is to safely convey stormwater inflows up to the peak 100 year ARI discharge into the pond or lake system with discharge from the pond or lake being via a combination of pipe (low flow) culvert and overflow spillway.

9.4.1.1 Flood Estimation

A range of hydrologic methods can be applied to estimate design flows. If the typical catchment areas are relatively small, the Rational Method Design Procedure is considered to be a suitable method for estimating design flows. However, the use of the Rational Design Procedure should strictly be used to size inlet hydraulic structures only and that a full flood routing computation method should be used in sizing the outlet hydraulic structures (e.g. outlet pipe, spillway and embankment height, etc.)

9.4.1.2 Waterbody residence time

As discussed earlier, a combination of inflow water quality, organic load and water circulation characteristics influence the water quality in the pond. Water quality problems for large lakes exhibiting relatively small upstream catchments typically arise because the water body receives insufficient water inflows to circulate and/or displace the water stored in the lake. Under long residence times blue green algae blooms can occur.

Experience with management of many open waterbodies suggests that many incidences of algal blooms in waterbodies are preceded by extended periods of no or minimal inflows. Waterbody residence time (or turnover frequency) analysis can often be a very useful indicator as to whether the waterbody is of significant risk of water quality problems (especially associated with algal growth). Appendix D discusses the risk of algal growth in more detail.

Turnover analysis can be undertaken using probabilistic monthly evaporation and rainfall data or daily historical rainfall data, with the latter providing a more rigorous analysis. Average residence times are calculated by modelling continuous simulation of flows into and out of a lake. Estimates of daily outflows are then summed (in arrears) to give an estimate of the average residence time of the lake for each day of the simulation

Seasonal distribution of rainfall and the relative volume of the waterbody to the mean annual runoff will determine the range of residence periods for the waterbody. For example, a small waterbody with a large catchment will have small residence times simply by the fact that the volume of the waterbody is a small fraction of the mean annual runoff volume of the catchment. On the other hand, the residence times of a larger waterbody will be more sensitive to seasonality of rainfall and thus a higher risk of long water detention periods and associated water quality problems.

A cumulative probability distribution of waterbody residence time can be derived using the modelled outflows from a lake. Figure 9.3 shows the results of an example residence time analysis for a waterbody in Melbourne.

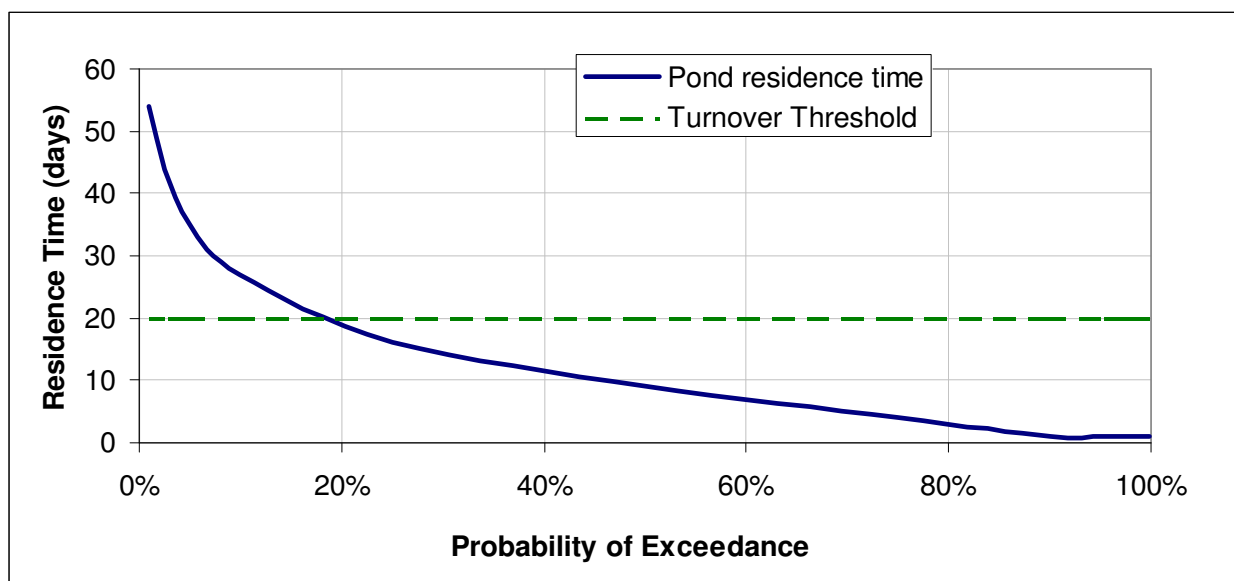

Figure 9.3. Results of residence time analysis for a waterbody in Melbourne

Algal growth can occur rapidly under favorable conditions. Nuisance growths (blooms) of cyanobacteria (Blue–green algae) can occur in both natural and constructed water bodies. In constructed water bodies it is important to ensure that designs include measures to restrict cyanobacterial growth. Cyanobacterial blooms can have adverse effects on aquatic ecosystem function, Aesthetics and public amenity. Some species of cyanobacteria are of particular concern because of their potential to produce toxins.

Many factors influence cyanobacterial growth including (Tarczynska *et al*, 2002; Mitrovic *et al*, 2001; Sherman *et al*, 1998; Reynolds, 2003):

- light intensity
- water temperature
- nutrient concentration
- hydrodynamics
- stratification
- catchment hydrology
- zooplankton grazing
- parasitism

Excessive growth of cyanobacterial species is considered an Alert Level 1 Algal Bloom when concentrations reach 15000 cells/mL (Government of Victoria, 'Blue–Green Algae' *Information Brochure*). Appendix D discusses these issues in more detail.

Assuming adequate light and nutrient availability, a model of algal growth can be developed using a simple relationship between time and growth rate at various temperatures (see Appendix D). This simple model can be used to determine how long it will take for an algal population to reach bloom proportions (15,000 cells/mL) and hence inform the development of guidelines on water body hydraulic detention time.

Modelling conducted and based on reasonable assumptions suggest the following times under ideal conditions for blooms to occur depending on mixing conditions (Appendix D).

Figure 9.4 and 9.5 were derived assuming a 'best practice' design of a pond. This includes shallow depth, have a flat bottom and are generally well mixed. A reasonable assumption is that the hydrodynamic conditions in a best management practice design varies somewhere between fully mixed and diurnally, partially mixed.

The curves represent three temperature zones relating to summer water temperature as follows:

- ▶ 15°C Use for upland sites in the Eastern and Western Ranges.
- ▶ 20°C Use for lowland sites south of the Great Dividing Range.
- ▶ 25°C Use for lowland sites north of the Great Dividing Range.

The modeling approach taken is considered to be reasonably conservative. For example it adopts:

- ▶ Non-limiting conditions for nutrient and light availability
- ▶ Growth rates for a known nuisance species (*Anabaena circinalis*)
- ▶ Summer temperature values (the main risk period)
- ▶ High starting population concentrations (50 cells/mL)

As a result, a probabilistic approach to the use of detention time criteria is recommended. A 20% exceedance is suggested as an acceptable risk to compensate for the occurrence of all other risk factors being favorable for algal growth. The 20% exceedance of a specific detention time objective does not indicate that a bloom will occur; just that detention time (for a given temperature range) is long enough for exponential growth to achieve a bloom alert level of 15,000 cells/mL if all other risk factors were favourable. The 20% exceedance value is an interim value chosen as a relatively conservative estimate of the general variation in ecological factors in the Australian environment.

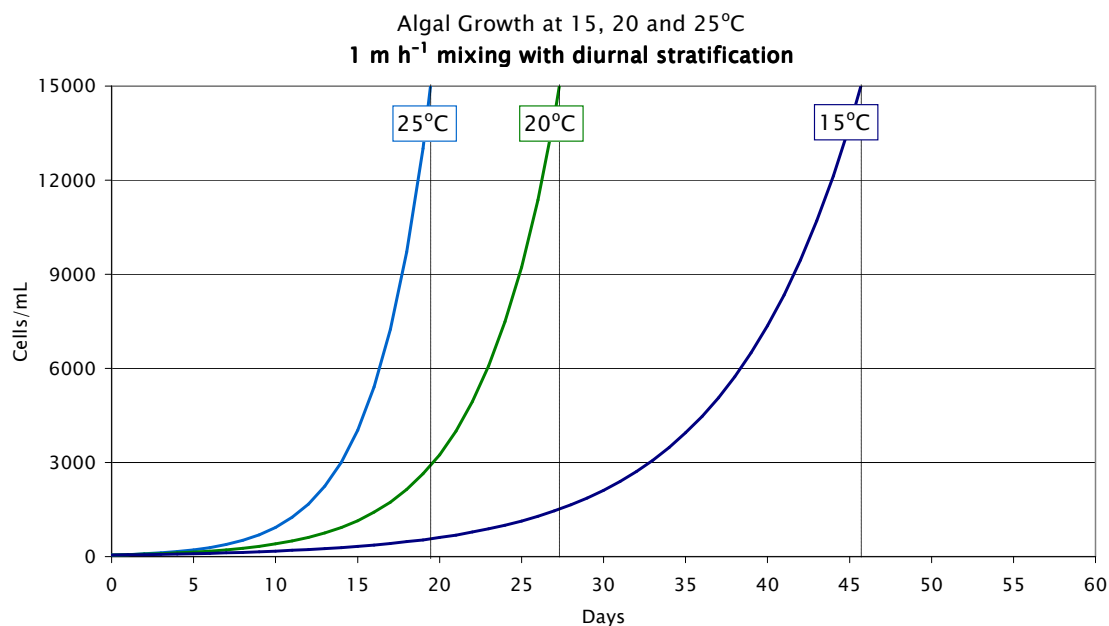

Figure 9.4. Growth curves illustrating modelled times for cyanobacterial populations to reach bloom proportions under different temperature conditions and 1 m h⁻¹ mixing conditions with diurnal stratification. Based on growth rates of *A. circinalis* measured *in situ* (Westwood and Ganf, 2004) adjusted for temperature, Q_{10} 2.9, and assuming 50 cells/mL starting concentrations.

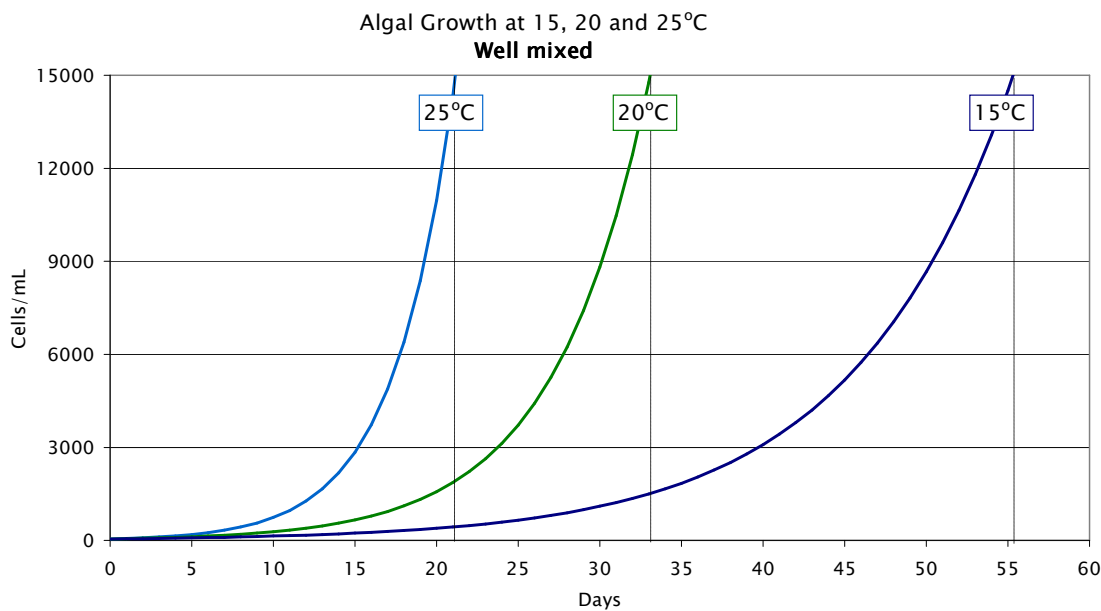

Figure 9.5. Growth curves illustrating modelled times for cyanobacterial populations to reach bloom proportions under different temperature conditions and well mixed conditions. Based on growth rates of *A. circinalis* measured *in situ* (Westwood and Ganf, 2004) adjusted for temperature, Q_{10} 2.9, and assuming 50 cells/mL starting concentrations.

9.4.1.3 Turnover design criteria

The following guideline detention times are recommended. For water bodies with summer water temperatures in the following ranges, the 20%tile detention times should not exceed:

- ▶ 50 days (15°C)
- ▶ 30 days (20°C)
- ▶ 20 days (25°C)

These values are broadly consistent with literature detention time values considered to be protective against the risk of cyanobacterial blooms (Reynolds 2003, Wagner–Lotkowska *et al* 2004) and consistent with current industry experience.

9.4.1.4 Lake Water Level Fluctuation Analysis

Water level fluctuation analysis is another important analysis that needs to be undertaken as they may have a significant influence on the landscape design of the lakes edge. As in the waterbody turnover analysis, lake water level analysis can be undertaken using probabilistic monthly evaporation and rainfall data or daily historical rainfall data, with the latter providing a more rigorous analysis. A variety of models can be used to predict water levels from continuous simulations (e.g. MUSIC). A typical analysis may be to determine the 10%tile, 50%tile and 90%tile water depths in a lake during summer.

The results of an analysis to ascertain the relationship between lake volume and probabilistic summer water levels for a proposed lake in Shepparton in Victoria are plotted below.

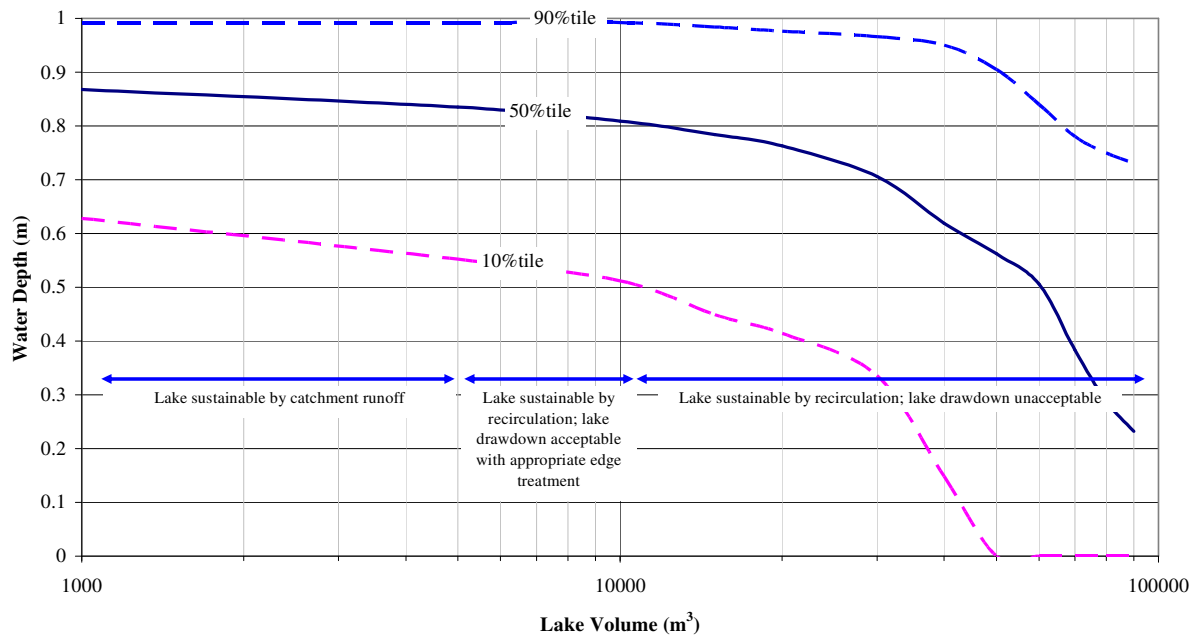

Figure 9.6. Analysis of Probabilistic Summer Water Depth with different Lake Volume for a proposed lake in Shepparton in Victoria

9.4.1.5 Option for a larger waterbody

Often much larger open waterbodies are proposed by landscape and urban designers as ornamental lakes while serving the function of stormwater quality improvement. This can mean further design and operation considerations necessary to maintain a healthy waterbody, to provide an acceptable low level of risk of algal growth.

If an analysis indicates that a waterbody is at significant risk of algal blooms (i.e. the *Turnover Design Criteria* are not met) a lake turnover strategy will need to be developed. In addition, a lake management plan may be required and involve more detailed modeling using such models as the Cooperative Research Centre for Freshwater Ecology’s Pond Model.

A re-circulating pump can be used to increase the turnover of a waterbody during the drier months such that it has an acceptable residence time (in accordance with the *Turnover Design Criteria*). The required pump rate is estimated as the lake volume divided by the required maximum residence time.

To re-circulate the lake water, it is necessary to pass the water through a wetland system to reduce nutrient levels in the water column and limit the growth of planktonic algae. The wetland should be designed in accordance to the design procedure for constructed wetlands (see Chapter 8) with a permanent pool that extends over the majority of the wetland area. The combined permanent pool and extended detention volume should be size to provide a recommended detention period of 5 days for the re-circulating pump rate to ensure adequate nutrient removal.

9.4.2 Pond Layout

9.4.2.1 Size and Dimensions

To optimise hydraulic efficiency, i.e. reduce short circuits and dead zones, it is desirable to adopt a high length to width ratio and to avoid zones of water stagnation. The ratio of length to width varies depending on the size of the system and the site characteristics while inlet and outlet conditions as well as the general shape of the pond can influence the presences and extent of water stagnation zones. To simplify the design and earthworks, smaller systems tend to have length to width ratios at the lower end of the range. This can often lead to poor hydrodynamic conditions.

Persson *et al* (1999) used the term hydraulic efficiency to define the expected hydrodynamic characteristics for a range of configurations of stormwater detention systems. Engineers Australia (2003) present expected hydraulic efficiencies of detention systems for a range of notional shapes, aspect ratios and inlet/outlet placements within stormwater detention systems and recommends that such systems should not have a λ value of less than 0.5 and should be designed to promote hydraulic efficiencies greater than 0.7 (see Figure 9.7).

λ is estimated from the configuration of the basin according to Figure 9.7.

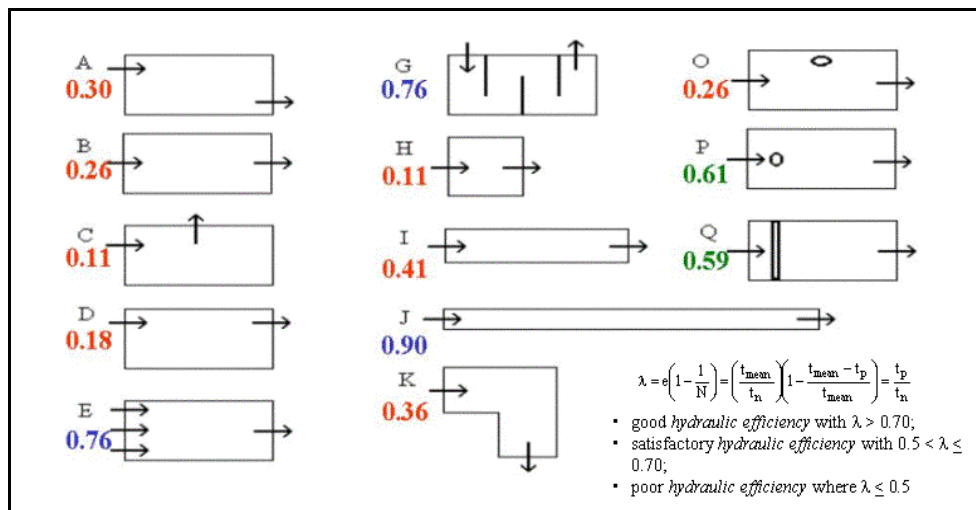

Figure 9.7. Hydraulic Efficiency - λ - A measure of Flow Hydrodynamic Conditions in Constructed Wetlands and Ponds; Range is from 0 to 1, with 1 representing the best hydrodynamic conditions for stormwater treatment (Persson et al., 1999)

The numbers in Figure 9.7 represent the values of λ that are used to estimate the turbulence parameter ‘n’ for Equation 9.2 (see next section).

Higher values (of λ) represent ponds with good sediment retention properties, where a value of λ greater than 0.5 should be a design objective. If the pond configuration yields a lower value, modification to the configuration should be explored to increase the λ value (e.g. inclusion of baffles, islands or flow spreaders).

There can often be multiple inlets into the waterbody and the locations of these inlets to the outlet structure can influence the hydraulic efficiency of the system. Inlet structures design

that reduce localized water eddies and promote good mixing of water within the immediate vicinity of the inlet may be necessary and the use of an inlet zone is a common approach to inlet design.

The shape of the pond also has a large impact on the effectiveness to retain sediments and generally a length to width ratio of at least 3:1 should be aimed for. In addition, the location of the inlet and outlet, flow spreaders and internal baffles impact the hydraulic efficiency of the basin for stormwater treatment. These types of elements are noted in Figure 9.7 as the figure “o” in diagrams O and P (which represent islands in a waterbody) and the double line in diagram Q which represents a structure to distribute flows evenly.

9.4.2.2 Inlet zone (or forebay)

It is good design practice to provide pre-treatment of stormwater to ponds and lakes for removal of sediment, organic matter and nutrients. The inlet zone can take many forms, ranging from systems that function as a sedimentation basin to that of a shallow ephemeral wetland. They are a transitional zone into the deeper waters of a pond.

Some inlet zones are constructed with a porous embankment at its transition with the deeper water zone to promote a wider distribution of inflow water across the open water body.

The bathymetry across the inlet zone is to vary gradually from 0.2 m above the permanent pool level to 0.3 m below the permanent pool level over a distance of between 10 m to 20 m.

There is generally little need for any hydraulic structures separating an inlet zone of a pond to the open water section, although a designer may consider the use of a porous embankment to promote better flow distribution into the open water zone. A low flow vegetated swale should be provided to convey dry weather flow and low flows to the open waterbody.

The notional required inlet zone area can be computed by the use of sedimentation theory (see Chapter 3), targeting the 125 µm sediment (settling velocity of 11 mm/s) operating at the 1 year ARI peak discharge.

The specification of the required area (A) of a sedimentation basin may be based on the expression by Fair and Geyer (1954), formulated for wastewater sedimentation basin design:

$$R = 1 - \left(1 + \frac{1}{n} \frac{v_s}{Q/A} \right)^{-n}$$

Equation 9.1

where	R	=	fraction of target sediment removed
	v_s	=	settling velocity of target sediment
	Q/A	=	rate of applied flow divided by basin surface area
	n	=	turbulence or short-circuiting parameter

The above expression for sedimentation is applied with ‘n’ being a turbulence parameter. Figure 9.7 provides guidance on selecting an appropriate ‘n’ value (according to the configuration of the basin). ‘n’ is selected using the following relationship:

$$\lambda = 1 - 1/n; \quad n = \frac{1}{1-\lambda}$$

Equation 9.2

Equation 9.1 is strictly applicable for systems with no permanent pool, and will generally over-estimate the required area of a sedimentation basin. This equation is thus often considered to provide an upper limit estimate of the required size for sedimentation basins.

Good practice in the design of inlet zone will include a permanent pool to reduce flow velocities and provide storage of settled sediment.

The presence of a permanent pool reduces flow velocities in the sedimentation basin and thus increases detention times. Owing to the outlet structure being located some distance above the bed of a sedimentation basin, it is also not necessary for sediment particles to settle to the bed of the basin to effectively retain the sediments. It is envisaged that sediments need only settle to an effective depth which is less than the depth to the bed of the sediment. This depth is considered to be approximately 1 m below the permanent pool level.

Equation 9.1 can thus be re-derived to account for the effect of the permanent pool storage as follows:

$$R = 1 - \left[1 + \frac{1}{n} \cdot \frac{v_s}{Q/A} \cdot \frac{(d_e + d_p)}{(d_e + d^*)} \right]^{-n}$$

Equation 9.3

where d_e is the extended detention depth (m) above the permanent pool level

d_p is the depth (m) of the permanent pool

d^* is the depth below the permanent pool level that is sufficient to retain the target sediment (m) – adopt 1.0 or d_p whichever is lower.

list the typical settling velocities of sediments.

Table 9-1 Settling velocities under ideal conditions

Classification of particle size	Particle diameter (µm)	Settling velocities (mm/s)
Very coarse sand	2000	200

Coarse sand	1000	100
Medium sand	500	53
Fine sand	250	26
Very fine sand	125	11
Coarse silt	62	2.3
Medium silt	31	0.66
Fine silt	16	0.18
Very fine silt	8	0.04
Clay	4	0.011

9.4.2.3 Cross Sections

Batter slopes on approaches and immediately under the water line have to be configured with consideration of public safety. Both hard and soft edge treatments can be applied to compliment the landscape of the surrounding area of a pond or lake. A soft edge treatment approach will involve a gentle slope to the water edge and extending below the water line be adopted before the batter slope steepen into deeper areas. This is illustrated in

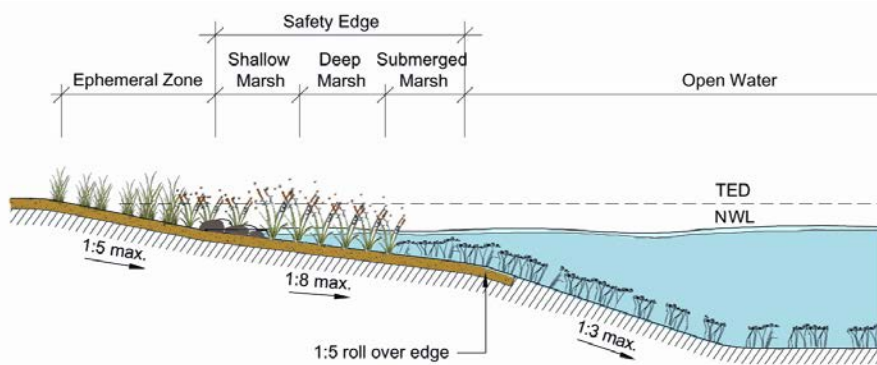

Figure 9.8 Illustration of a soft edge treatment for ponds and lakes (GbLA, 2004)

An alternative to the adoption of a flat batter slope beneath the water line is to provide a 3 m “safety bench” that is less than 0.2 m deep below the permanent pool level be built around the waterbody.

Figure 9.9 shows an option for a hard edge detail, using a vertical wall and has an associated handrail for public safety. This proposal uses rock to line the bottom of the pond to prevent vegetation (particularly weed) growth.

The safety requirements for individual ponds and lakes may vary from site to site, and it is recommended that an independent safety audit be conducted of each design.

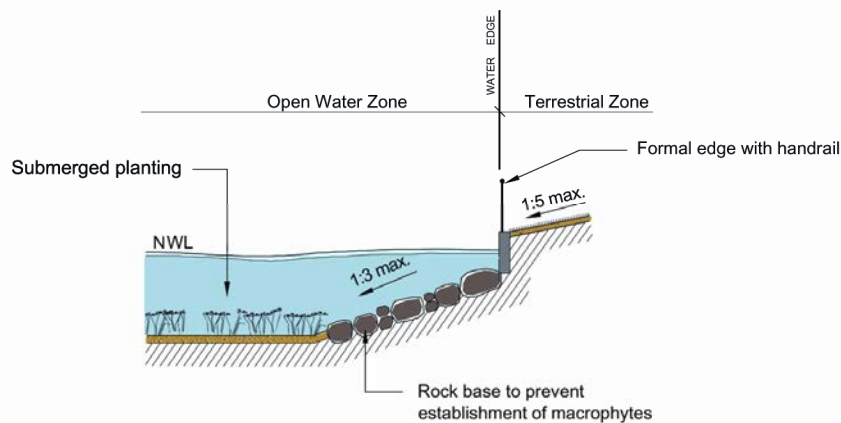

Figure 9.9 Illustration of hard edge treatment for open waterbodies (GbLA, 2004)

9.4.3 Hydraulic Structures

Hydraulic structures are required at the inlet and outlet of a pond or lake. Their function is essentially one of conveyance of flow with provisions for (i) energy dissipation at the inlet structure(s) and (ii) extended detention (if appropriate) at the outlet.

9.4.3.1 Inlet Structure

Discharge of stormwater into the open waterbody of a pond or lake may be via an inlet zone or direct input. In both cases it will be necessary to ensure that inflow energy is adequately dissipated so as not to cause localised scour in the vicinity of the pipe outfall. Design of stormwater pipe outfall structures are common hydraulic engineering practice.

Litter control is normally required at the inlet structure and it is generally recommended that some form of gross pollutant trap be installed as part of the inlet structure. There are a number of proprietary products for capture of gross pollutants and these are discussed in Chapter 7 in Australian Runoff Quality (Engineers Australia, 2006). The storage capacity of gross pollutant traps should be sized to ensure that maintenance (clean-out) frequency is not greater than 1 every 3 months.

9.4.3.2 Outlet Structure

The outlet structure of a pond or lake can be configured in many ways and is dependent on the specified operation of the system during periods of high inflows. Many ponds form part of a flood retarding basin in which case the outlet structure consist of two components, i.e. outlet pit and outlet culvert. The computation of the required outlet culvert is an essential element of the retarding basin design and will be based on flood routing computation as outlined in ARR. The main function of the inlet pit is to maintain the desired permanent pool level and to provide a means of connecting the maintenance pipe to the outlet culvert. Design considerations of the outlet pit include the following:

- Ensure that the crest of the pit is set at the permanent pool level of the lake or pond

- Ensuring that the dimension of the pit provides discharge capacity that is greater than the discharge capacity of the outlet culvert or pipe
- Protection against clogging by flood debris

The dimension of an outlet pit is determined by considering two flow conditions, weir and orifice flow (Equations 9.4 and 9.5)

A blockage factor is also used to account for any debris blockage. Assuming the pit is 50% blocked is recommended. Generally it will be the discharge pipe from the inlet zone (and downstream water levels) that controls the maximum flow rate from the area, it is therefore less critical if the outlet pit is oversized to allow for blockage.

1. Weir flow condition – when free overall conditions occur over the pit (usually when the extended detention storage of the retarding basin is not fully engaged), ie.

$$P = \frac{Q_{des}}{B \cdot C_w \cdot H^{1.5}}$$

Equation 9.4

- P = Perimeter of the outlet pit
- B = Blockage factor (0.5)
- H = Depth of water above the crest of the outlet pit
- Q_{des} = Design discharge (m³/s)
- C_w = weir coefficient (1.7)

2. Orifice flow conditions – when the inlet pit is completely submerged (corresponding to conditions associated with larger flood events), ie.

$$A_o = \frac{Q_{des}}{B \cdot C_d \sqrt{2gH}}$$

Equation 9.5

- C_d = Orifice Discharge Coefficient (0.6)
- B = Blockage factor (0.5)
- H = Depth of water above the centroid of the orifice (m)
- A_o = Orifice area (m²)
- Q_{des} = Design discharge (m³/s)

Whichever conditions calculates the largest required pipe should be adopted. It is important that an outlet pit is prevented from blockage by debris. Design consideration needs to include means of preventing blockage of the outlet structure.

Outlet culvert of pipe capacity is estimated using the orifice equation (10.5) without a blockage factor.

9.4.3.3 *Maintenance Drain*

The waterbody should be able to be drained for maintenance with manual operation. A suitable design flow rate is one which can draw down the permanent pool within seven days although, depending on the volume of the waterbody, this may not be realistic.

The orifice discharge equation (Equation 9.5) is considered suitable for sizing the maintenance drain (without blockage factor) on the assumption that the system will operate under inlet control.

9.4.4 High-flow route design

The provision of a high-flow route is standard design practice to ensure that overflow from the dam embankment can be safely conveyed either by the use of a spillway or ensuring that the embankment is designed to withstand overtopping. This issue requires specialised design inputs and are not discussed in this document.

9.4.5 Vegetation specification

Vegetation planted along the littoral zone of a pond or lake serves the primary function of inhibiting public access to the open waterbody. Terrestrial planting beyond the littoral zone may also be recommended to screen areas and provide an access barrier to uncontrolled areas of the stormwater treatment system.

Plant species for the inlet zone area will be predominantly of ephemeral wetland species. The reader is referred to the Appendix B for a list of suggested plant species suitable for the inlet zone and littoral zones in Victoria and recommended planting densities.

9.4.6 Design Calculation Summary

Overleaf is a design calculation summary sheet for the key design elements of a construction wetland to aid the design process.

Ponds and Lakes	CALCULATION SUMMARY	
CALCULATION TASK	OUTCOME	CHECK
1 Identify design criteria		<input type="checkbox"/>
Design ARI Flow for inlet hydraulic structures	year	
Design ARI Flow for outlet hydraulic structures	year	
Design ARI for emergency hydraulic structures	days	
80%tile turnover period	m	
Probabilistic summer water level – 10%tile	m	
Probabilistic summer water level – 90%tile	m ³	
Flood Detention Storage Volume (from flood routing analysis)	mm	
Outlet pipe dimension (from flood routing analysis)		
2 Catchment characteristics		<input type="checkbox"/>
Residential	Ha	
Commercial	Ha	
Fraction impervious		<input type="checkbox"/>
Residential		
Commercial		
3 Estimate design flow rates		
Time of concentration		
estimate from flow path length and velocities	minutes	<input type="checkbox"/>
Identify rainfall intensities		
station used for IFD data:		
Design Rainfall Intensity for inlet structure(s)	mm/hr	<input type="checkbox"/>
Design runoff coefficient		
inlet structure(s)		<input type="checkbox"/>
Peak design flows		
Inlet structure(s)	m ³ /s	<input type="checkbox"/>
Outlet structure(s)	m ³ /s	
4 Forebay Zone Layout		<input type="checkbox"/>
Area of Forebay Zone	m ²	
Aspect Ratio	L:W	
Hydraulic Efficiency		
5 Lake Residence Time		<input type="checkbox"/>
Is wetland forebay for recirculation required		
Area of wetland forebay for water recirculation	m ²	
Detention time during recirculation of wetland forebay	days	
Lake water recirculation pump rate	L/s	
6 Pond Layout		<input type="checkbox"/>
Area of Open Water	m ²	
Aspect Ratio	L:W	
Hydraulic Efficiency		
Length	m	
Width	m	
Cross Section Batter Slope	V:H	
7 Hydraulic Structures		
Inlet Structure		<input type="checkbox"/>
Provision of energy dissipation		
Outlet Structure		<input type="checkbox"/>
Pit dimension	L x B	
Discharge capacity of outlet pit	mm diam	
Provision of debris trap	m ³ /s	
Maintenance Drain		<input type="checkbox"/>
Diameter of Maintenance Valve	mm	
Drainage time	days	

9.5 Checking tools

This section provides a number of checking aids for designers and referral authorities. In addition, advice on construction techniques and lessons learnt from building lake systems are provided.

Checklists are provided for:

- Design assessments
- Construction (during and post)
- Operation and maintenance inspections
- Asset transfer (following defects period).

9.5.1 Design assessment checklist

The checklist below presents the key design features that should be reviewed when assessing a design of a lake. These considerations include configuration, safety, maintenance and operational issues that should be addressed during the design phase.

Where an item results in an “N” when reviewing the design, referral should be made back to the design procedure to determine the impact of the omission or error.

In addition to the checklist, a proposed design should have all necessary permits for its installations. The referral agency should ensure that all relevant permits are in place. These can include permits to clear vegetation, to dredge, create a waterbody, divert flows or disturb fish or platypus habitat.

Land ownership and asset ownership are key considerations prior to construction of a stormwater treatment device. A proposed design should clearly identify the asset owner and who is responsible for its maintenance. The proposed owner should be responsible for performing the asset transfer checklist (see 9.5.4).

Pond and Lake Design Assessment Checklist			
<i>Lake Location:</i>			
<i>Hydraulics</i>	Minor Flood: (m ³ /s)	Major Flood (m ³ /s):	
Inlet Zone		Y	N
Inlet pipe/structure sufficient for maximum design flow (Q ₅ or Q ₁₀₀)?			
Scour protection provided at inlet structures?			
Configuration of forebay zone (aspect, depth and flows) allows even distribution of inflow into open water zone?			
Maintenance access provided?			
Public access to forebay zone managed through designated pathways?			
Gross pollutant protection measures provided on inlet structures?			
Open Water Zone		Y	N
Depth of open water > 1.5 m?			
Aspect ratio provides hydraulic efficiency >0.5?			
Depth of permanent water >1.5m?			
20% probability of exceedance in accordance with guidelines (i.e. 20, 30 or 50 days)			
Edge treatment – Batter slopes from accessible edges shallow enough to allow egress?			
Edge treatment – provision of littoral zone planting with 1:8 batter slopes to 0.2 m below the waterline ?			
Edge treatment – vertical fall to shallow bench?			
Maintenance access provided?			
Public access to open zones restricted to designated pathways with appropriate safety considerations?			
Embankment height > flood detention depth?			
Lake turnover management plan developed (if turnover is inadequate)?			
Probabilistic summer water level fluctuation within desired range and edge treatment developed to suit?			
Outlet Structures		Y	N
Outlet pit set at permanent water level?			
Discharge capacity of outlet pit > computed discharge capacity of outlet pipe? (checked against weir flow and orifice flow operating conditions)			
Maintenance drain provided?			
Protection against clogging of outlet pit provided?			

9.5.2 Construction advice

This section provides general advice for the construction of lakes. It is based on observations from construction projects around Australia.

Protection from existing flows

It is important to have protection from upstream flows during construction of a lake or pond system. A mechanism to divert flows around a construction site, protect from litter and debris is required. This can be achieved by constructing a high flow bypass channel initially and then diverting all inflows along the channel until the pond system is complete.

High flow contingencies

Contingencies to manage risks associated with flood events during construction are required. All machinery should be stored above acceptable flood levels and the site stabilised as best possible at the end of each day as well as plans for dewatering following storms made.

Erosion control

Immediately following earthworks it is good practice to revegetate all exposed surfaces with sterile grasses (e.g. hydroseed). These will stabilise soils, prevent weed invasion yet not prevent future planting from establishing.

Inlet erosion checks

It is good practice to check the operation of inlet erosion protection measures following the first few rainfall events. It is important to check for these early in the systems life, to avoid continuing problems. Should problems occur in these events the erosion protection should be enhanced.

Inlet zone access

An important component of an inlet zone (or forebay) is accessibility for maintenance. Should excavators be capable of reaching all parts of the inlet zone an access track may not be required to the base of the inlet zone, however an access track around the perimeter of the inlet zone is required. If sediment collection is by using earthmoving equipment, then a stable ramp will be required into the base of the inlet zone (maximum slope 1:10).

Inlet zone base

To aid maintenance it is recommended to construct the inlet zone either with a hard (i.e. rock or concrete) bottom or a distinct sand layer. These serve an important role for determining the levels that excavation should extend to during sediment removal (i.e. how deep to dig) for either systems cleaned from the banks or directly accessed. Hard bases are also important if maintenance is by driving into the basin.

Dewatering collected sediments

An area should be constructed that allows for dewatering of removed sediments from an inlet zone. This area should be located such that water from the material drains back into the inlet zone. Material should be allowed to drain for a minimum of overnight before disposal.

Timing for planting

Timing of vegetation planting is dependent on a suitable time of year (and potential irrigation requirements) as well as timing in relation to the phases of development. Temporary sediment controls should always be used prior to planting as lead times from earthworks to planting are often long.

Vegetation establishment

During the establishment phase water levels should be controlled carefully to prevent seedlings from being desiccated or drowned. This is best achieved with the use of maintenance drains. Once established, water levels can be raised to operational levels. This issue is further discussed in Appendix B.

Bird protection

Bird protection (e.g. nets) should be considered for newly planted area of wetlands, birds can pull out young plants and reduce plant densities.

Trees on embankments

Consideration should be given to the size of trees planted on embankments as root systems of larger trees can threaten the structural integrity of embankments.

9.5.3 Construction checklist

CONSTRUCTION INSPECTION CHECKLIST Ponds and Lakes

INSPECTED BY:
DATE:
TIME:
WEATHER:
CONTACT DURING VISIT:

SITE: _____

CONSTRUCTED BY: _____

DURING CONSTRUCTION									
Items inspected	Checked		Satisfactory	Unsatisfactory	Structural components	Checked		Satisfactory	Unsatisfactory
Preliminary works	Y	N			15. Location and levels of outlet as designed	Y	N		
1. Erosion and sediment control plan adopted					16. Safety protection provided				
2. Limit public access					16. Safety protection provided				
3. Location same as plans					17. Pipe joints and connections as designed				
4. Site protection from existing flows					18. Concrete and reinforcement as designed				
5. All required permits in place					19. Inlets appropriately installed				
Earthworks					20. Inlet energy dissipation installed				
6. Integrity of banks					21. No seepage through banks				
7. Batter slopes as plans					22. Ensure spillway is level				
8. Impermeable (eg. clay) base installed					23. Provision of maintenance drain(s)				
9. Maintenance access for inlet zone					24. Collar installed on pipes				
10. Compaction process as designed					26. Protection of riser from debris				
11. Placement of adequate topsoil (edges)					Vegetation				
12. Levels as designed for base, benches, banks and spillway (including freeboard)					29. Vegetation appropriate to zone (depth)				
13. Check for groundwater intrusion					30. Weed removal prior to planting				
14. Stabilisation with sterile grass					31. Provision for water level control during establishment				
					32. Vegetation layout and densities as designed				

FINAL INSPECTION									
	Y	N	Satisfactory	Unsatisfactory		Y	N	Satisfactory	Unsatisfactory
1. Confirm levels of inlets and outlets					9. Check for uneven settling of banks				
2. Confirm structural element sizes					10. Evidence of stagnant water or short circuiting				
3. Check batter slopes					11. Evidence of litter or excessive debris				
4. Vegetation planting as designed					12. Provision of removed sediment drainage area				
5. Erosion protection measures working					13. Outlet free of debris				
6. Pre-treatment installed and operational									
7. Maintenance access provided									
8. Public safety adequate									

COMMENTS ON INSPECTION								

ACTIONS REQUIRED								
1.								
2.								
3.								
4.								
5.								

9.5.4 Asset transfer checklist

Asset Handover Checklist		
<i>Asset Location:</i>		
<i>Construction by:</i>		
<i>Defects and Liability Period</i>		
Treatment	Y	N
System appears to be working as designed visually?		
No obvious signs of under-performance?		
Maintenance	Y	N
Maintenance plans provided for each asset?		
Inspection and maintenance undertaken as per maintenance plan?		
Inspection and maintenance forms provided?		
Asset inspected for defects?		
Asset Information	Y	N
Design Assessment Checklist provided?		
As constructed plans provided?		
Copies of all required permits (both construction and operational) submitted?		
Proprietary information provided (if applicable)?		
Digital files (eg drawings, survey, models) provided?		
Asset listed on asset register or database?		

9.6 Maintenance requirements

Pond and lakes treat runoff by providing extended detention and allowing sedimentation to occur. In addition, they have a flow management role that needs to be maintained to ensure adequate flood protection for local properties.

The majority of lake maintenance is associated with the inlet zone (and GPT if installed). Weeding, planting and debris removal are the dominant tasks. In addition, if artificial turnover of the lake is required (because of long residence times) a mechanical system will need to be employed and will require specific maintenance.

Edge vegetation will also require maintenance including weed removal and replanting. Other components of the system that will require careful consideration are the inlet points. Inlets

can be prone to scour and build up of litter. Occasional litter removal and potential replanting may be required as part of maintaining an inlet zone.

Maintenance is primarily concerned with:

- Maintenance of flow to and through the system
- Maintaining vegetation
- Removal of accumulated sediments and litter and debris

Similar to other types of stormwater practices, debris removal is an ongoing maintenance function. Debris, if not removed, can block inlets or outlets, and can be unsightly if located in a visible location. Inspection and removal of debris should be done regularly, but debris should be removed whenever it is observed on the site.

Inspections are also recommended following large storm events to check for scour.

9.6.1 Operation & maintenance inspection form

The form below should be used whenever an inspection is conducted and kept as a record on the asset condition and quantity of removed pollutants over time.

Pond Maintenance Checklist			
Inspection Frequency:	3 monthly	Date of Visit:	
Location:			
Description:			
Site Visit by:			
Inspection Items	Y	N	Action Required (details)
Litter within inlet or open water zones?			
Sediment within inlet zone requires removal (record depth, remove if > 50%)?			
Overflow structure integrity satisfactory?			
Evidence of dumping (building waste, oils etc)?			
Terrestrial vegetation condition satisfactory (density, weeds etc)?			
Replanting required?			
Submerged/floating vegetation requires removal/harvesting (if > 50%)?			
Settling or erosion of bunds/batters present?			
Damage/vandalism to structures present?			
Outlet structure free of debris?			
Maintenance drain operational (check)?			
Comments:			

9.7 Worked example

9.7.1 Worked example introduction

As part of a residential development in Hobart, a permanent waterbody is proposed to treat runoff from a residential area of 110 Ha (45% catchment imperviousness) and provide landscape amenity as an integral component of the public open space. The residential development is to have a number of stormwater quality improvement measures within the streetscape. A pond is expected to reduce the nitrogen load from the catchment by 10%.

This pond is to be nested within the site of a flood retarding basin. The site for the retarding basin is 4.2 Ha in area and is quadrangle in shape as shown in Figure 9.10. A combination of active and passive open space (urban forestry, pond etc.) functions are to be incorporated into the site.

Stormwater is conveyed by stormwater pipes (up to the 10 year ARI event) and by designated floodways (including roadways) for events larger than the 10 year ARI event. There are four sub-catchments discharging into the retarding basin. During the design 100 year ARI event, the maximum discharge from the retarding basin is 4.1 m³/s.

9.7.2 Design Considerations

Design considerations include the following:

1. Verifying the size of the pond (depth and area).
2. Computation to ensure that the pond volume is not excessive large in comparison to the hydrology of the catchment.
3. Configuring the layout of the pond such that the system *hydraulic efficiency* can be optimised, including the transition structure between the inlet zone and the open waterbody
4. Design of hydraulic structures
 - a. inlet structure to provide for energy dissipation of inflows up to the 100 year ARI peak discharge
 - b. Design of the pond outlet structure for the pond and retarding basin.
5. Landscape design
 - a. Edge treatment
 - b. Recommended plant species and planting density
6. Maintenance provisions

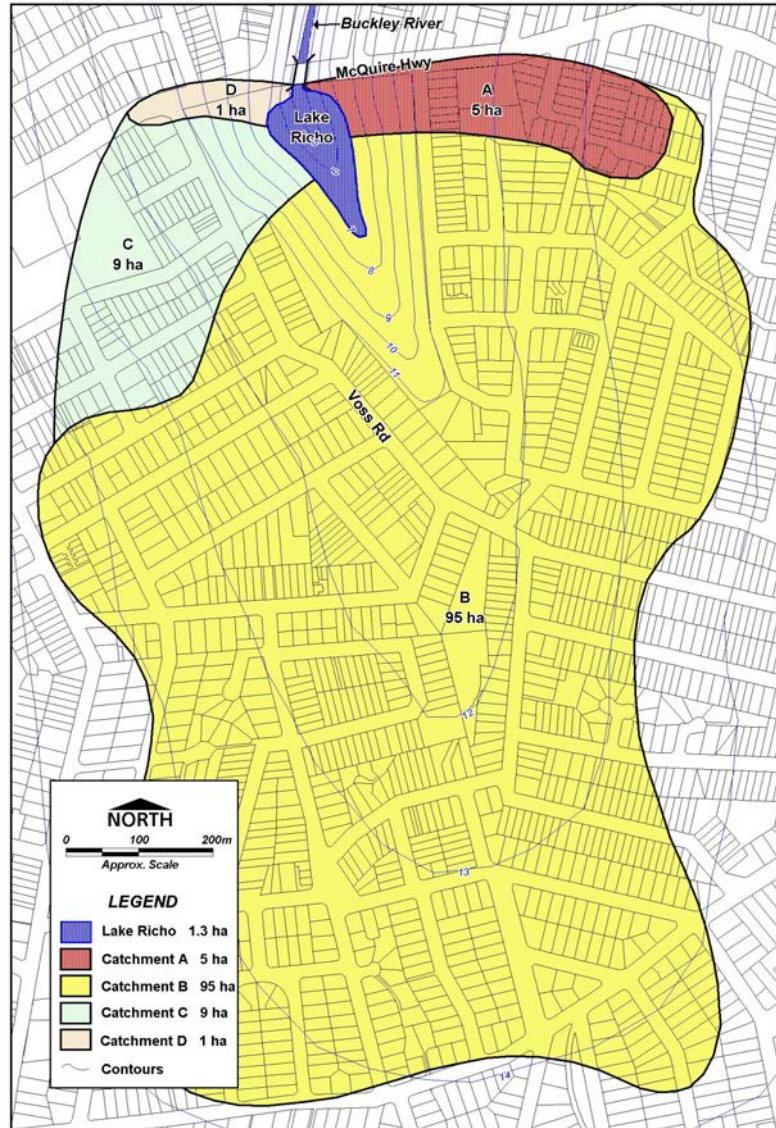

Figure 9.10 Proposed site for Retarding Basin and Pond

9.7.3 Confirming Pond Area

As a basic check of the adequacy of the size of the lake, reference is made to the performance curves presented in 9.3 Verifying size for treatment. According to Figure 9.1, the required lake area necessary to reduce TN load by 10% is approximately 0.35% of the impervious area of the catchment.

The required lake area computed from the simple procedure presented in Chapter 3 is as follows:

Catchment area = 110Ha (45% impervious)

Therefore Impervious Area = 50 Ha

Required Lake Area (2.0m mean depth) is:

$$\begin{aligned} \text{Impervious Area (m}^2\text{)} \times \text{treatment area required (\%)} &= 500000 \times 0.0035 \\ &= 1750 \text{ m}^2 \end{aligned}$$

Note: This area should be converted to a site-specific area using the appropriate adjustment factor / hydrologic region relationship.

DESIGN NOTE – The values derived from Figure 9.1 will only be valid if the design criteria for the proposed installation are similar to those used to create the Figures. Site specific modelling using programs such as MUSIC (eWater, 2009) may yield a more accurate result.

The proposed lake area is 3000 m², the proposed permanent pool level is 5.5 m–AHD with a maximum depth of 2.5 m and a depth range between 1.5 m and 2.5 m. The volume of the proposed lake waterbody is approximately 6 ML (ie. 0.3 Ha area x 2 m depth). The layout of the proposed waterbody is shown in Figure9.11.

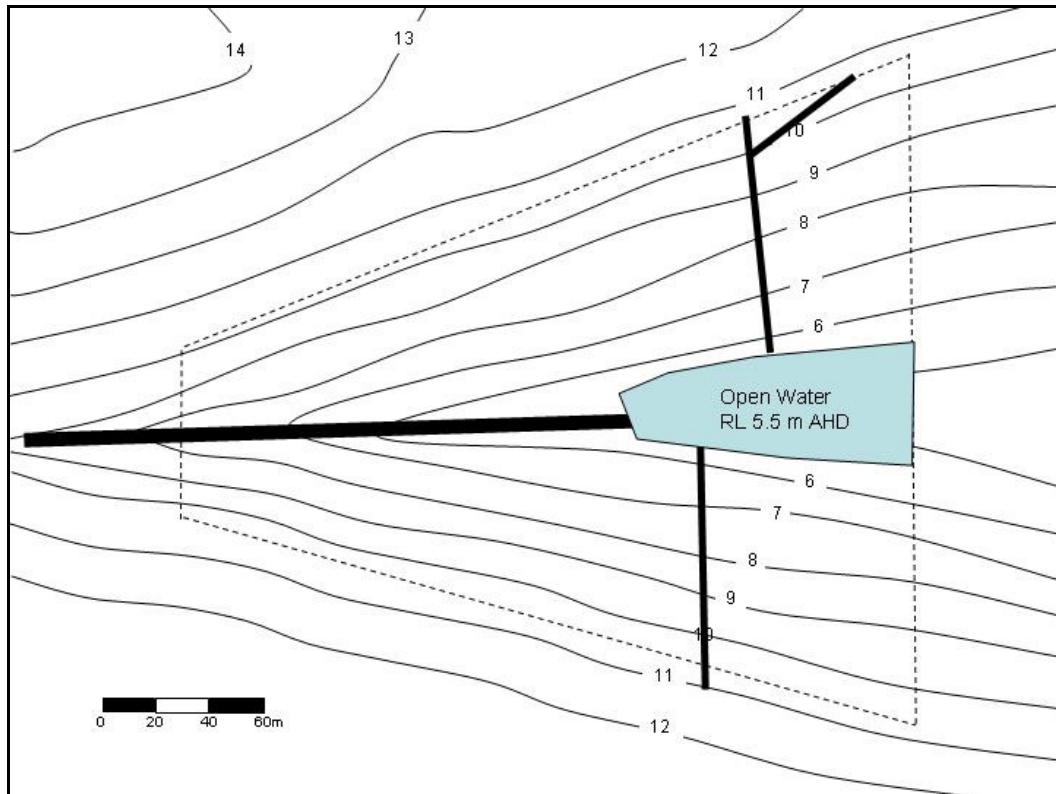

Figure 9.11 Layout of Proposed Pond

- Proposed pond area is 3000 m² is confirmed as larger than the expected size required to achieve the 10% reduction in TN proposed
- Permanent Pool Level is set at 5.5 m–AHD
- Lake volume ~ 6 ML

9.7.4 Design calculations

9.7.4.1 *Lake Hydrology*

Waterbody residence time analysis

Waterbody residence time analysis should be undertaken using a continuous simulation approach with the use of historical rainfall data with historical potential evaporation data or probabilistic monthly potential evaporation estimates (see Section 9.3.1). A simplified approach may be undertaken as a preliminary assessment of the adequacy of waterbody turnover in the first instance. This is outlined below.

The statistics of the monthly rainfall and areal potential evapo–transpiration data are summarised in Table 9-2 below.

**** For the purposes of this worked example, the figures in Table 9.2 are adopted as being the actual data for this area.**

Table 9-2 Meteorological Data

	Jan	Feb	Mar	Apr	May	Jun	
Mean Rainfall (mm)	35.2	33.5	43	65.3	88.9	100.1	
Median Rainfall (mm)	25.9	25.8	36.9	61.9	82.1	96.5	
Decile 9 Rainfall (mm)	74.7	72.6	83.6	110.2	145.6	153.7	
Decile 1 Rainfall (mm)	9.4	5.9	12.1	25.6	36	56.4	
Mean No. of Raindays	8.7	8	11.4	14.7	18.4	19.6	
Monthly Areal PET (mm)	150	120	100	85	40	30	
	Jul	Aug	Sep	Oct	Nov	Dec	Annual
Mean Rainfall (mm)	108.5	107.6	85.1	70.4	53.2	44.7	835.5
Median Rainfall (mm)	102.8	102.6	81.4	67.5	48.9	38.6	834.9
Decile 9 Rainfall (mm)	167.2	165.1	126.6	111.9	93.4	81.8	1001.4
Decile 1 Rainfall (mm)	57	55.5	53.4	29.2	22	13.8	656.6
Mean No. of Raindays	21.1	21.2	18.5	16.2	13	11.3	182.1
Monthly Areal PET (mm)	30	45	70	100	125	135	1000

From the above meteorological data, a simple assessment can be made of the waterbody residence times for the 10%ile, 50%ile and 90%ile summer meteorological conditions. This can be done by computing the ratio of net summer inflow to the pond volume and subsequently dividing the number of days over the summer period (92 days) with this ratio.

	Summer Rainfall (mm)	Net Summer Inflow (ML)¹	Net Summer Inflow Lake Volume	Summer Probabilistic Residence Time (days)
10%tile	29.1	13.3	2.2	~41 days
50%tile	90.3	43.6	7.3	~ 13 days
90%tile	229	112	18.7	~5 days

¹Catchment Inflow (~Rainfall x Impervious Area)–net evaporation (~[Evaporation – Rainfall] x Lake Area)

The 20%tile residence time can be estimated by interpolating between the 10%tile value and the 50%tile value. The interpolation is best undertaken using a log–normal probability plot.

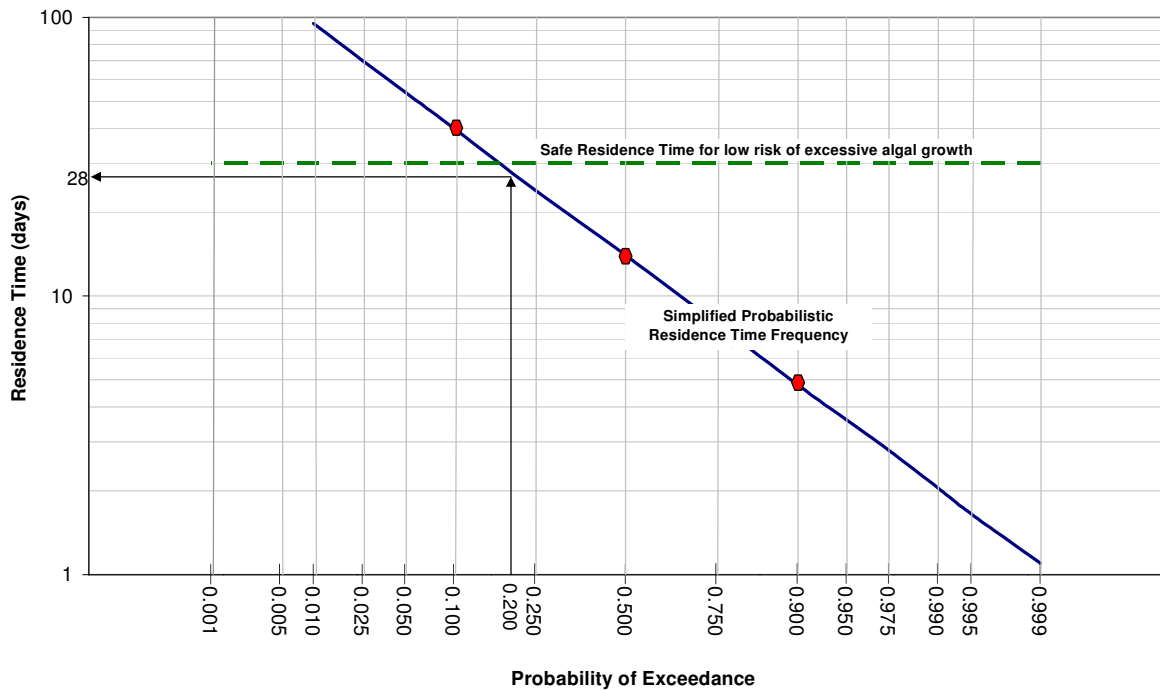

Figure 9.12 Simplified Log-normal probability plot of summer pond probabilistic residence time

The analysis undertaken indicated that the proposed pond has a 20 percentile probabilistic residence time of approximately 28 days. This is just within the guidelines for sustainable ecosystem health of a waterbody of 30 days and it is advisable that a continuous simulation of pond residence time be undertaken to confirm that the pond has a low risk of eutrophication.

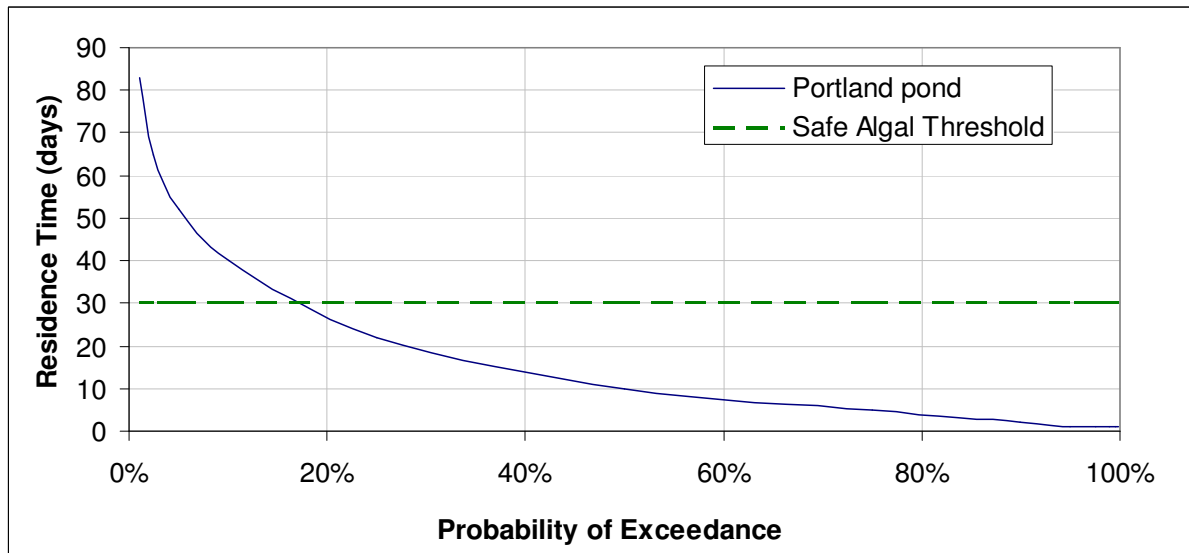

Figure 9.13 Plot of probabilistic residence time determined from continuous simulation using 25 years of rainfall record

☐ There is no significant risk of summer algal bloom with the proposed pond volume.

Probabilistic Summer Water Levels

Water level fluctuation over the summer period is influenced by catchment inflow and evaporation from the lake waterbody. As is the case for the waterbody turnover analysis, a rigorous approach to determination of the probabilistic summer water level fluctuation is through a continuous simulation approach using a daily timestep.

A simplified approach to determine if water level fluctuation is excessive within the water body can be undertaken by examining the 10%tile monthly water balance. Figure 9.14 shows the plot of the 10% catchment inflow to the lake and the average monthly evaporative losses from the lake. The adoption of the average monthly evaporative losses are not expected to significantly under-estimate the evaporative loss corresponding to a 10%tile hydrologic scenario.

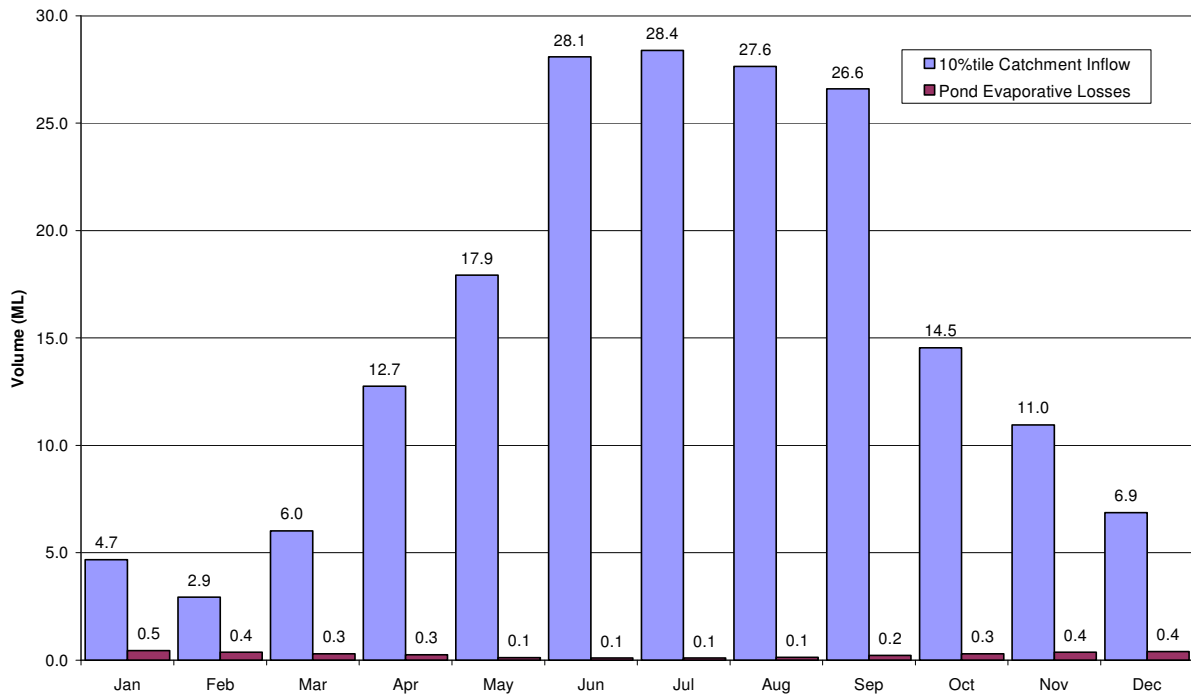

Figure 9.14 Lake water budget (10%ile catchment rainfall)

The analysis shows that monthly catchment inflow exceeds evaporative losses in all months indicating that even for the 10%tile rainfall scenario, the lake level can be expected to be at full level at least on one occasion each month. The maximum fluctuation in water level (corresponding to the January/February period) can be conservatively computed to be the sum of the expected evaporation losses of these two months, e.g. approximately 250 mm.

Lake water level fluctuation is not expected to be a significant Aesthetic issue for the proposed lake.

Estimating Design Flows

Times of concentration have been assessed by assuming pipe and overland flow velocities of 1 m/s and estimating flow paths. In smaller catchments, a minimum time of concentration of 6 minutes has been adopted to allow for lot scale impacts. The characteristics of each catchment are summarised in

Rainfall intensities were estimated using IFD intensities for Portland and are also summarised below.

Table 10.3 Catchment Characteristics, Rainfall Intensities and Design Discharges

Sub Catchment	Area (Ha)	Flow Path Length (m)	t_c (min)	I_1	C_1	Q_1	I_{10}	C_{10}	Q_{10}	I_{100}	C_{100}	Q_{100}
A	5	220	7	34	0.59	0.28	63	0.74	0.65	144	0.88	1.78
B	95	1400	30	17	0.39	1.73	30	0.49	3.84	64	0.59	9.93
C	9	200	7	34	0.59	0.50	63	0.74	1.17	144	0.88	3.20
D	1	150	7	34	0.59	0.06	63	0.74	0.13	144	0.88	0.36

Runoff coefficients for the 1 year, 10 year and 100 year ARI events for the catchments (each with a 0.45 fraction impervious) were calculated in accordance to the procedure in AR&R 1998 (Book 8) and are also summarised.

9.7.4.2 Open Water Zone Layout

Size and Dimensions

The open water zone will be quadrangular in shape to conform to the natural terrain of the site. The general dimension is a mean width of 30 m and 100 m along the long axis, giving an aspect ratio of 3(L) to 1(w). With the largest of the catchment discharging into the lake from one end of the longer axis, the expected hydraulic efficiency of the open water body can be up to of the order of 0.34 unless the outlet from sub-catchment B can be designed such that outflow is uniformly distributed across the 20 m wide foreshore of the pond. This can be achieved by designing a vegetated swale transition between the pipe outfall and the forebay of the pond.

*Aspect Ratio is 3(L) to 1(W);
Hydraulic Efficiency ~0.76 with distributed inflow*

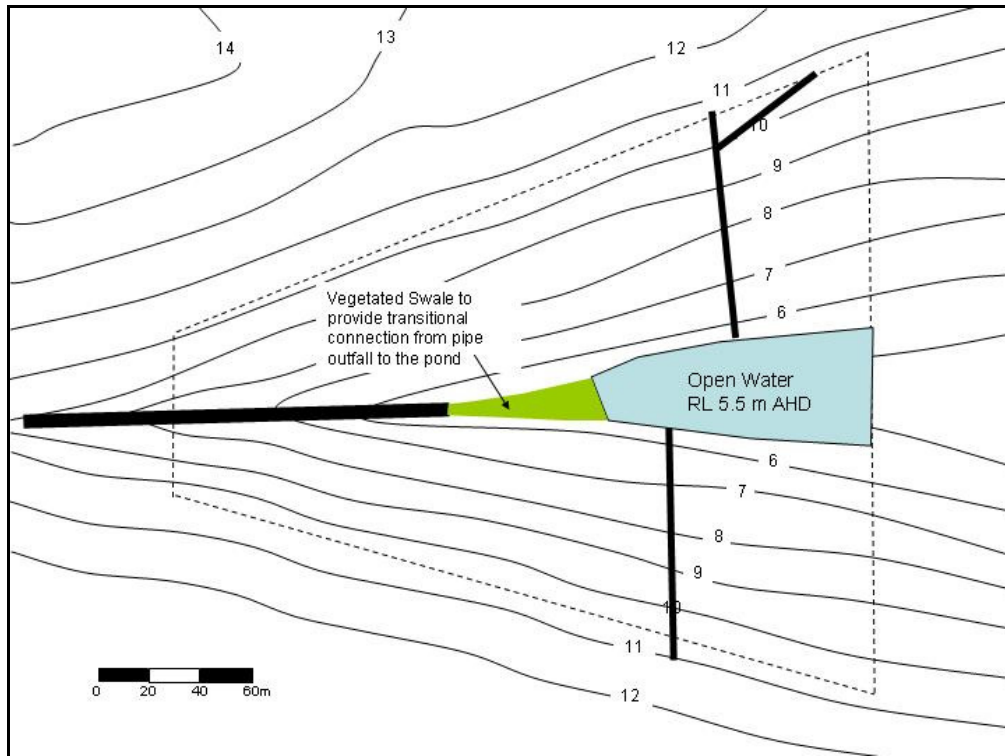
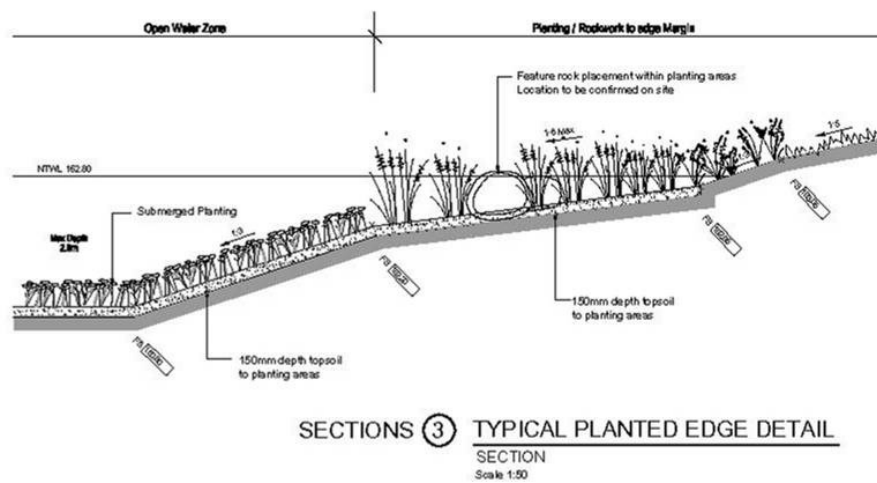

Figure 9.15 Vegetated swale recommended to provide flow transition from pipe outfall to foreshore of pond

Section

The long and cross sections of the pond will follow the natural terrain with limited requirement for earthworks to form the bathymetry of the pond.

The batter slopes on approaches and immediately under the permanent water level have to be configured with consideration of public safety. A batter slope of 1(V):8(H) from the littoral zone to 0.3 m beneath the water line before steepening into a 1(V):3(H) slope is



recommended as a possible design solution (see illustration below).

Cross section of littoral zone to below the water line consists of a 1:8 batter slope to 0.3 m below the permanent pool level

9.7.4.3 Pond Outlet Structure

Maintenance Drain

A maintenance drain will be provided to allow drainage of the system. Valves will be operated manually to drain the permanent waterbody. The drawdown period should be of the order of 24 hours if practical.

The mean flow rate for the maintenance drain is selected to drawdown the permanent pool over 24 hours is computed as follows:

$$\text{Permanent Pool Volume} \sim 6,000 \text{ m}^3$$

$$Q = 6000 / (1 \times 24 \times 3600) = 0.07 \text{ m}^3/\text{s} = 70 \text{ L/s}$$

It is reasonable to assume that the valve orifice will operate under inlet control with its discharge characteristics determined by the orifice Equation 9.5, i.e.

$$A_o = \frac{Q}{C_d \sqrt{2gh}}$$

$$Q = 0.07 \text{ m}^3/\text{s}$$

$$C_d = 0.6$$

$$H = 0.67 \text{ m (two thirds of maximum permanent pool depth)}$$

Giving $A_o = 0.02 \text{ m}^2$ corresponding to an orifice diameter of 161 mm
adopt 200 mm maintenance pipe

*Pipe valve to allow draining of the permanent pool for maintenance to be **at least 200 mm diameter.***

Outlet Pit

The outlet pit is to be set at a crest level at the nominated permanent pool level of 5.5 m AHD. The discharge capacity of the outlet pit must be at least equal but preferably higher than the design retarding basin outflow.

During the 100 year ARI operation of the retarding basin, the outlet pit will be completely submerged and the required dimension of the outlet pit to discharge 4.1 m³/s can be computed using the orifice flow Equation 9.5, i.e.

$$A_o = \frac{Q_{des}}{BC_d \sqrt{2gH}}$$

$$B = \text{Blockage factor}$$

C_d = Orifice Discharge Coefficient (0.6)

H = 3.5 m

A_o = Orifice area (m²)

Q_{des} = 4.1 m³/s

The computed plan area of the overflow pit is 1.65 m². The nominal pit dimension to ensure adequate discharge capacity is 2.0 m x 1.0 m.

Outlet pit dimension is 2.0 m x 1.0 m

9.7.4.4 High-flow route and spillway design

The spillway weir level is set at RL 11.0 m AHD and the retarding basin embankment height is approximately 7 m. It will be necessary to design the spillway with adequate capacity to safely convey peak discharges up to the Probable Maximum Flood (PMF). This requires specialist hydrological engineering input involving flood estimation and flood routing calculations.

The spillway needs to be designed to safely convey discharges up to the Probable Maximum Flood.

9.7.4.5 Vegetation Specifications

The vegetation specification and recommended planting density for the littoral and open water zone are summarised in the table below.

Zone	Plant Species	Planting Density (plants/m ²)
Littoral berm	<i>Persicaria decipens</i>	3
Open water zone	<i>Vallisneria spiralis</i>	4

The reader is referred to Appendix B for further discussion and guidance on vegetation establishment and maintenance.

9.7.4.6 Design Calculation Summary

Ponds and Lakes		CALCULATION SUMMARY		
CALCULATION TASK		OUTCOME		CHECK
1 Identify design criteria				<input checked="" type="checkbox"/>
Design ARI Flow for inlet hydraulic structures		10	year	
Design ARI Flow for outlet hydraulic structures		100		
Design ARI for emergency hydraulic structures		PMF	year	
80%tile summer turnover period		>>110	days	
Probabilistic summer water level – 10%tile		7.2	m	
Probabilistic summer water level – 90%tile		7.5	m	
Flood Detention Storage Volume (from flood routing analysis)		150000	m ³	
Outlet pipe dimension (from flood routing analysis)		750	mm	
2 Catchment characteristics				<input checked="" type="checkbox"/>
	Residential	110	Ha	
	Commercial	0	Ha	
Fraction impervious				<input checked="" type="checkbox"/>
	Residential	0.45		
	Commercial	N/A		
3 Estimate design flow rates				
Time of concentration				
estimate from flow path length and velocities		7 to 30	minutes	<input checked="" type="checkbox"/>
Identify rainfall intensities				
	station used for IFD data:	Portland		
	Design Rainfall Intensity for inlet structure(s)	30 to 63	mm/hr	<input checked="" type="checkbox"/>
Design runoff coefficient				
	inlet structure(s)	0.49 to 0.74		<input checked="" type="checkbox"/>
Peak design flows				<input checked="" type="checkbox"/>
	Inlet structure(s)	0.13 to 3.84	m ³ /s	
	Outlet structure(s)	4.100	m ³ /s	
4 Forebay Zone Layout				<input checked="" type="checkbox"/>
	Area of Forebay Zone	15 to 125	m ²	
	Aspect Ratio	2(L):1(W)	L:W	
	Hydraulic Efficiency	0.4		
5 Lake Residence Time				<input checked="" type="checkbox"/>
	Is wetland forebay for recirculation required	Y		
	Area of wetland forebay for water recirculation	10000	m ²	
	Detention time during recirculation of wetland forebay	5	days	
	Lake water recirculation pump rate	17	L/s	
6 Pond Layout				<input checked="" type="checkbox"/>
	Area of Open Water	22000	m ²	
	Aspect Ratio	2(L):1(W)	L:W	
	Hydraulic Efficiency	0.76		
	Length	200	m	
	Width	50 to 150	m	
	Cross Section Batter Slope	1(V):8(H)	V:H	
7 Hydraulic Structures				
Inlet Structure				<input checked="" type="checkbox"/>
	Provision of energy dissipation	Y		
Outlet Structure				<input checked="" type="checkbox"/>
	Pit dimension	1 x 1	L x B mm diam	
	Discharge capacity of outlet pit	4.1	m ³ /s	
	Provision of debris trap	Y		
Maintenance Drain				<input checked="" type="checkbox"/>
	Diameter of Maintenance Valve	200	mm	
	Drainage time	7	days	

9.7.5 Example Maintenance Schedule

The following is an example inspection sheet developed for a lake at Portland showing local adaptation to incorporate specific features and configuration of individual lakes. The following inspection sheet was developed from the generic lake maintenance inspection form.

PORTLAND LAKE – MAINTENANCE FORM		
Location		
Description	Constructed lake and sediment forebay	
SITE VISIT DETAILS		
Site Visit Date:	_____	
Site Visit By:	_____	
Weather	_____	
Purpose of the Site Visit	Tick Box	Complete Sections
Routine Inspection	<input type="checkbox"/>	Section 1 only
Routine Maintenance	<input type="checkbox"/>	Section 1 and 2
Cleanout of Sediment	<input type="checkbox"/>	Section 1, 2 and 3
Annual Inspection	<input type="checkbox"/>	Section 1, 2, 3 and 4
SECTION 1 INSPECTION		
Gross Pollutant Load cleanout required?	Yes/No _____	
Depth of Sediment in Forebay:	_____ m	
Cleanout required if Depth of Sediment \geq 1.0 m	Yes/No _____	
Any weeds or litter in wetland (If Yes, complete Section 2 Maintenance)	Yes/No _____	
Any visible damage to wetland or sediment basin? (If Yes, completed Section 4 – Condition)	Yes/No _____	
Inspection Comments:		
SECTION 2 MAINTENANCE		
Are there weeds in the wetland forebay and littoral zone?	Yes/No _____	

Were the weeds removed this site visit?	Yes/No	
Is there litter in the lake or forebay?	Yes/No	
Was the litter collected this site visit?	Yes/No	
SECTION 3a CLEANOUT OF GROSS POLLUTANTS		
Have the following been notified of cleanout date?	Yes	No
Coordinator – open space and/or drainage	<input type="checkbox"/>	<input type="checkbox"/>
Local Residents	<input type="checkbox"/>	<input type="checkbox"/>
Other (specify)	<input type="checkbox"/>	<input type="checkbox"/>
Method of Cleaning (excavator or eductor)		
Volume of Gross Pollutant and Sediment Removed (approximate estimate) m³		
Any visible damage to gross pollutant trap? (If yes, complete Section 4 Condition)	Yes/No	
SECTION 3b CLEANOUT OF SEDIMENT		
Have the following been notified of cleanout date?	Yes	No
Coordinator – open space and/or drainage	<input type="checkbox"/>	<input type="checkbox"/>
Local Residents	<input type="checkbox"/>	<input type="checkbox"/>
Other (specify)	<input type="checkbox"/>	<input type="checkbox"/>
Method of Cleaning (excavator or eductor)		
Volume of Sediment Removed (approximate estimate) m³		
Any visible damage to wetland or sediment forebay? (If yes, complete Section 4 Condition)	Yes/No	

SECTION 4 CONDITION					
Component	Checked?		Condition OK?		Remarks
	Yes	No	Yes	No	
Inlet structures					
Outlet structures					
Sediment forebay					
Spillway and spillway channel					
Forebay and littoral zone vegetation					
Banks and batter slopes					
Forebay bunds or porous embankment (if constructed)					
Retarding Basin embankment					
Surrounding landscaping					
Comments:					

9.8 References

- Atlas, R.M. and Bartha, R., 1998, *Microbial Ecology, Fundamentals and Applications*, Fourth Edition, Benjamin/Cummings Science Publishing, California
- Chorus, I. and Bartram, J. (Eds), 1999, *Toxic Cyanobacteria in Water: A guide to their public health consequences, monitoring and management*, E & FN Spon, London, on behalf of the World Health Organisation
- Engineers Australia, 2006, *Australian Runoff Quality Australian Runoff Quality: A guide to Water Sensitive Urban Design*, Editor-in-Chief, Wong, T.H.F.
- eWater, 2009, Model for Urban Stormwater Improvement Conceptualisation (MUSIC) User Manual, Version 4.0, September.
- Fair G.M. and Geyer J.C., 1954, *Water Supply and Waste Disposal*, John Wiley and Sons, New York, Vol. 2
- GbLA Landscape Architects, 2004, *Preliminary drawings for Mernda Wetland*, Report for Stockland
- Government of Victoria, 1995, *'Blue-Green Algae' Information Brochure*, Victorian Project Team on Blue-Green Algae, Department of Conservation and Natural Resources, Melbourne
- Harris G.P., 1996, 'Catchments and Aquatic Ecosystems: Nutrient ratios, flow regulation and ecosystem impacts in rivers like the Hawkesbury-Nepean', *Cooperative Research Centre for Freshwater Ecology Discussion Paper June 1996*, CRC for Freshwater Ecology, University of Canberra, Canberra
- Institution of Engineers Australia, 1997, *Australian Rainfall and Runoff - A guide to flood estimation*, Editor in Chief - Pilgram, D.H.
- Mitrovic, S.M., Bowling, L.C. and Buckney, R.T., 2001, *Vertical disentrainment of Anabaena circinalis in the turbid, freshwater Darling River, Australia: quantifying potential benefits from buoyancy*, *Journal of Plankton Research*, **23** (1): 47-55
- Persson, J., Somes, N.L.G. and Wong T.H.F., 1999, *Hydraulic efficiency and constructed wetland and ponds*, *Water Science and Technology* Vol 40 No 3 pp 291-289
- Reynolds, C.S., 2003, *The development of perceptions of aquatic eutrophication and its control*, *Ecohydrology and Hydrobiology* **3**(2): 149-163
- Sherman, B.S., Webster, I.T., Jones, G.J., Oliver, R.L., 1998, 'Transitions between *Aulacoseira* and *Anabaena* dominance in a turbid river weir pool' *Limnology and Oceanography* **43**(8): 1902-1915
- Tarczynska, M., Frankiewicz, P., Zalewski, M., 2002, The Regulation and Control of Hydrologic and Biotic Processes within Reservoirs for Water Quality Improvement. In: *Guidelines for the Integrated Management of the Watershed - Phytotechnology and Ecohydrology*, Freshwater Management Series No. 5, UNEP-IETC and UNESCO-IHP

Wagner-Lotkowska, I., Izydorczyk, K., Jurczak, T., Tarczynska, M., Frankiewicz, P. and Jorgensen, S.E., 2004, *Reservoir & Lake Management: Improvement of Water Quality*, In: Zalewski, M. (Ed) *Integrated Watershed Management - Ecohydrology and Phytotechnology - Manual*, United Nations Publication, United Nations Environment Programme.

Westwood, K.J. and Ganf, G.G., 2004, *Effect of cell flotation on growth of Anabaena circinalis under diurnally stratified conditions*, Journal of Plankton Research, JPR Advance Access June 17, 2004