

Chapter 6 Sand Filters

Definition:

A sand filter is a filter bed used to remove pollutants.

Purpose:

- To capture gross pollutants
- To retain coarse sediments
- Fine filtration of flows

Implementation considerations:

- They are particularly useful in areas where space is a premium and treatment is best achieved underground
- Due to the absence of vegetation, they require regular maintenance to ensure the surface of the sand filter media remains porous and does not become clogged with accumulated sediments.
- Prior to entering a sand filter, flows are generally subjected to a pretreatment to remove litter, debris and coarse sediments (typically a sedimentation chamber).
- Sand filters operate in a similar manner to bioretention systems with the exception that they have no vegetation growing on their surface. This is because they are either installed underground (therefore light limits vegetation growth) or the filter media does not retain sufficient moisture.



Sand filters can be installed above or below ground

6.1	Introduction	6-3
6.2	Verifying size for treatment	6-5
6.3	Design procedure: sand filters	6-7
6.4	Checking tools	6-15
6.5	Maintenance requirements	6-20
6.6	Sand filter worked example.....	6-22
6.7	References	6-33

6.1 Introduction

Sand filters operate in a similar manner as bioretention systems with the exception that they do not support any vegetation owing to the filtration media being too free-draining (and therefore dries out too frequently to support vegetation). Their use in stormwater management is suited to confined spaces and where vegetation cannot be sustained (e.g. underground). They are particularly useful treatment devices in heavily urbanized and built up areas.

Key design considerations include the provision of detention storage to yield a high hydrologic effectiveness (i.e. allowing for extended detention above the filter media), discharge control by proper sizing of the perforated underdrain and overflow pathway for above design operation.

A sand filter system typically consists of three chambers as illustrated below.

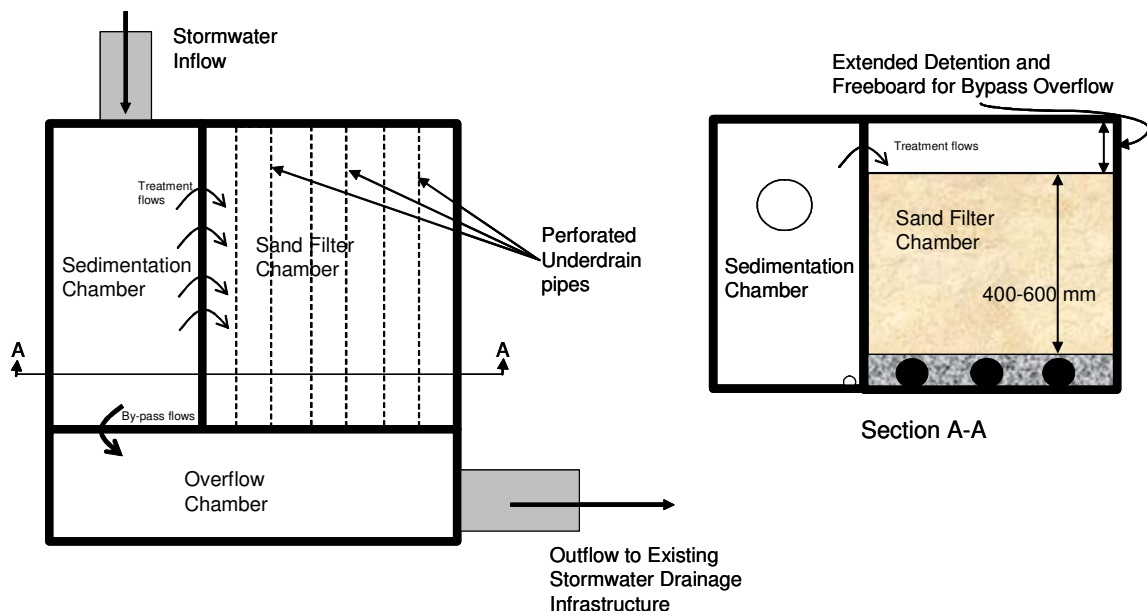

Figure 6.1. Typical layout of a sand filter

Functionality

Water enters a sedimentation chamber either via a conventional side entry pit or through an underground pipe network, where gross pollutants and coarse to medium-sized sediment is retained. This chamber can be designed to either have permanent water storage between events or to drain between storm events via weep holes.

Stormwater overflows from the sedimentation chamber into a sand filter chamber via a weir.

Water percolates through the sand filtration media (typically 400–600 mm depth) and perforated under-drain pipes collect filtered water in a similar manner as in bioretention systems.

There are advantages and disadvantages with either approach –

	<i>Advantages</i>	<i>Disadvantages</i>
<i>PERMANENT WATER STORAGE</i>	<ul style="list-style-type: none"> • Reduces the likelihood of re-suspension of sediments at the start of the following rainfall event as inflows do not fall and scour collected sediments • Minimised potential for mosquito breeding because of the likelihood of sufficient surface oil on incoming flows to prevent larval growth. 	<ul style="list-style-type: none"> • System requires the removal of wet material from the sedimentation chamber during maintenance. • The high organic loads and stagnant water can lead to anaerobic conditions that can also lead to release of soluble pollutants (such as phosphorous). Release of these bio-available pollutants can cause water quality problems downstream (such as excessive algal growth).
<i>FREE DRAINING</i>	<ul style="list-style-type: none"> • Allowing the sedimentation chamber to drain during inter-event periods (by installation of weep holes) reduces the likelihood of pollutant transformation during the inter-event period. 	<ul style="list-style-type: none"> • The challenge with this type of system is to design weep holes such that they can continue to drain as material (litter, organic material and sediment) accumulates and the holes do not block.

Figure 6.2 shows a sand filter in Auckland and Figure 6.3 shows an illustration of how a sand filter may be configured and operates during storm events.



Figure 6.2. Underground sand filter for a car park in Auckland, New Zealand

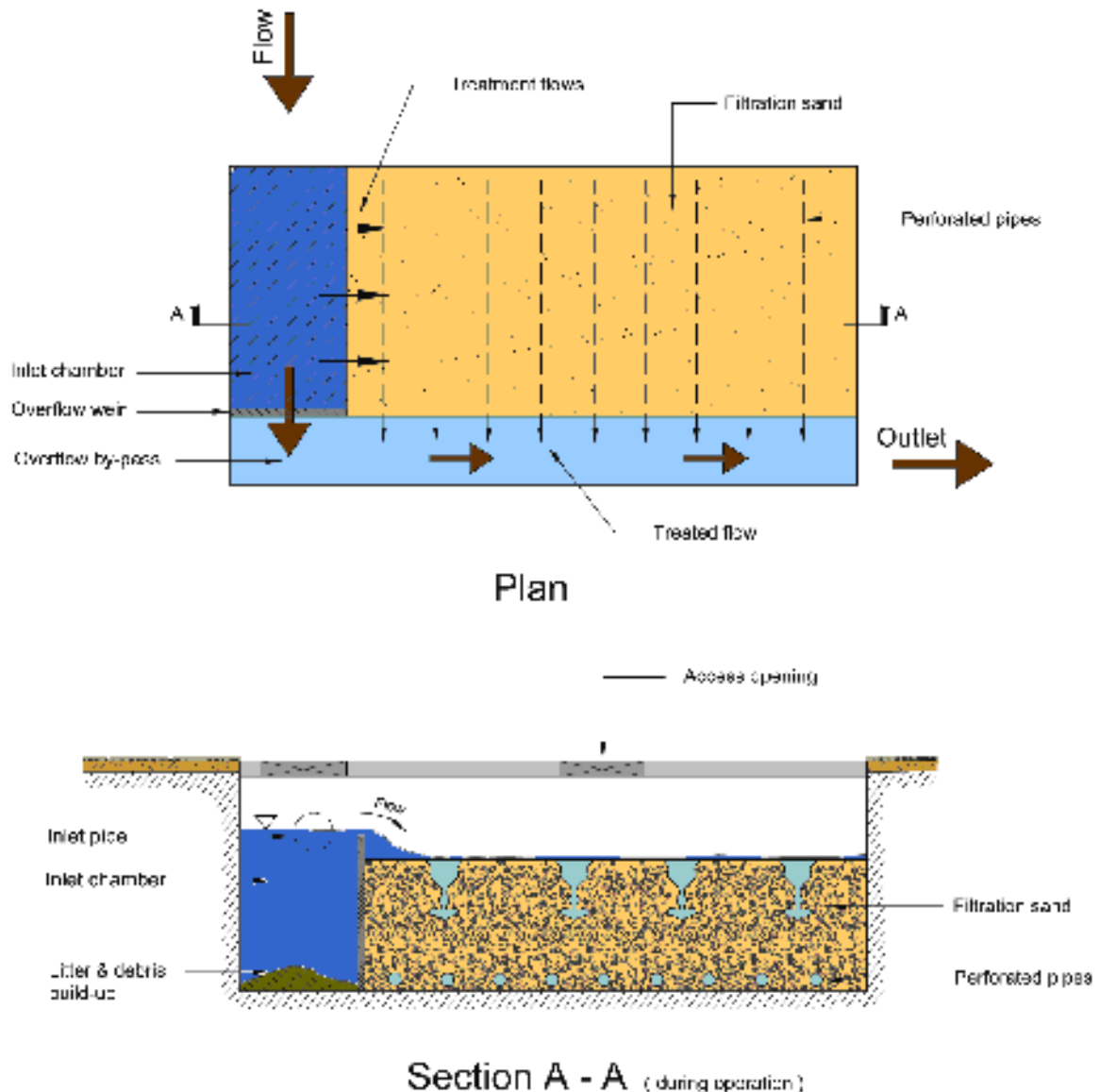

Figure 6.3. Illustration of a sand filter during operation

Key functions of a sand filter include the following:

- ▶ capture of gross pollutants
- ▶ sedimentation of particles larger than $125\ \mu\text{m}$ within a sedimentation chamber for flows up to a 1 year ARI (unattenuated) peak discharge
- ▶ filtration of stormwater following sedimentation pre-treatment through a sand filtration layer.

6.2 Verifying size for treatment

The graphs below show expected performance of sand filters for retention of TSS, TP and TN respectively. These curves were derived using MUSIC (eWater, 2009) an assumed sand filter depth of 600 mm. Note, Melbourne hydrological data was used in developing these curves for the sizing of sand filters.

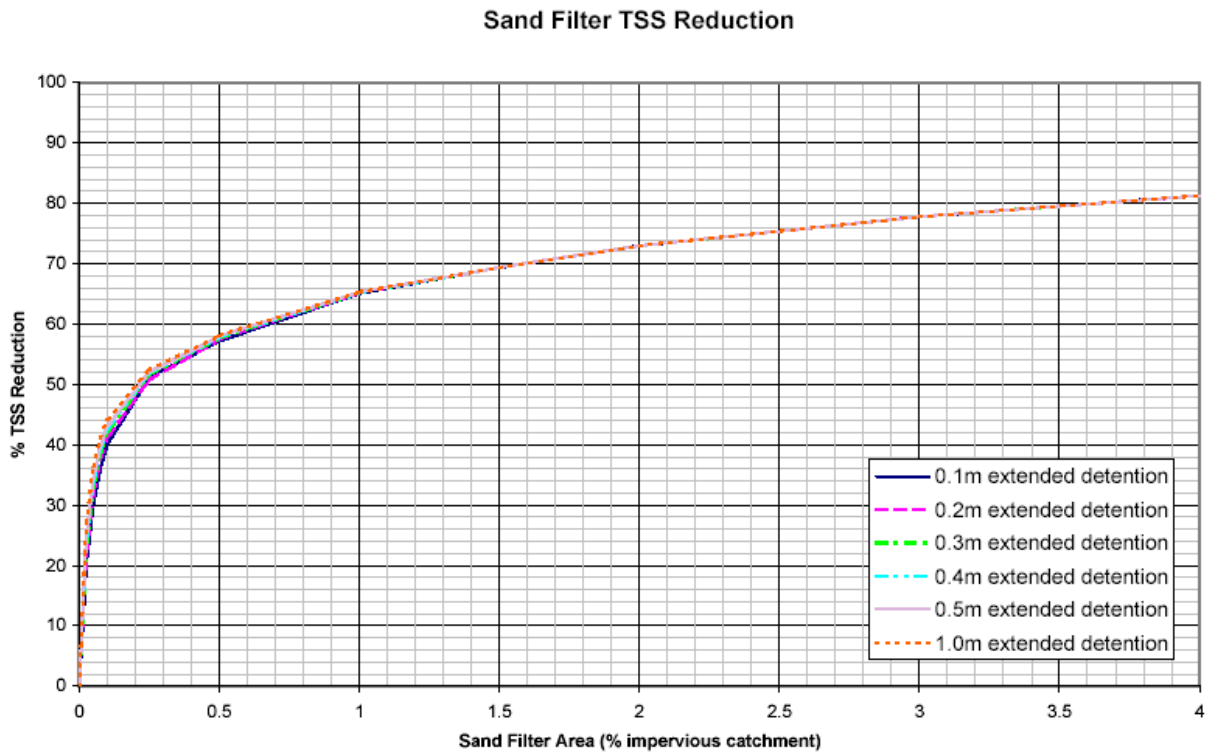

Figure 6.4. Sand Filter TSS removal performance

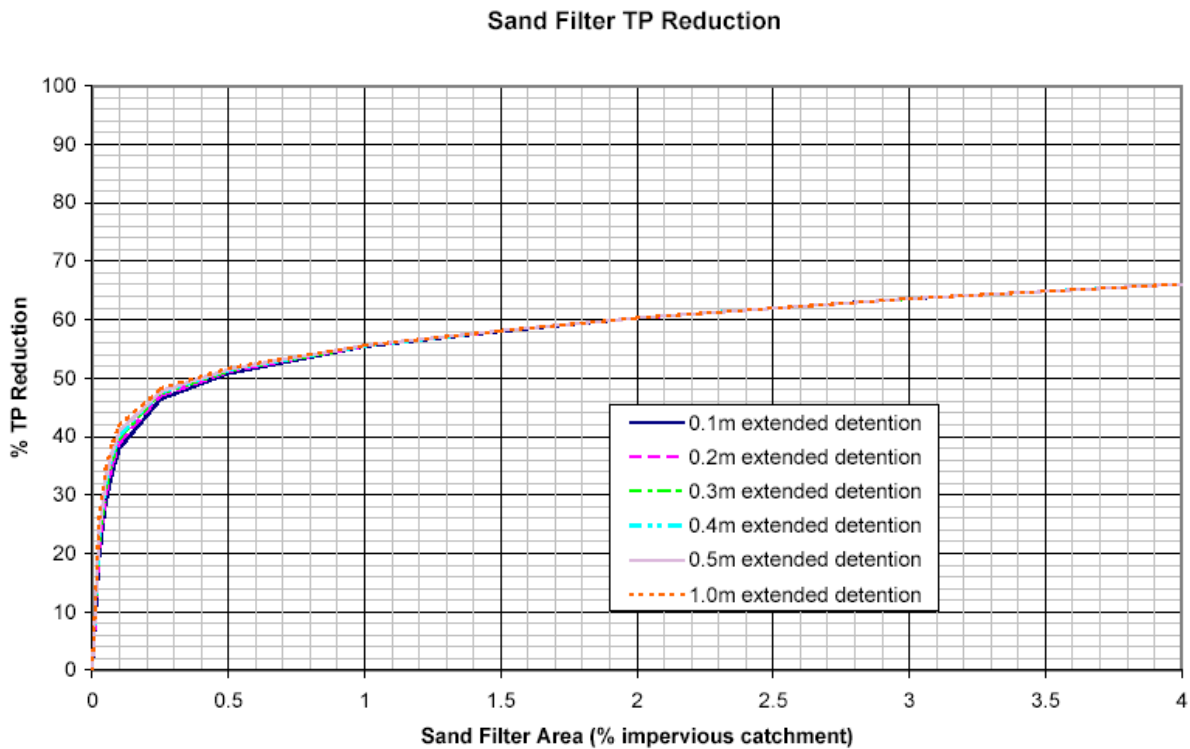

Figure 6.5. Sand Filter TP removal performance

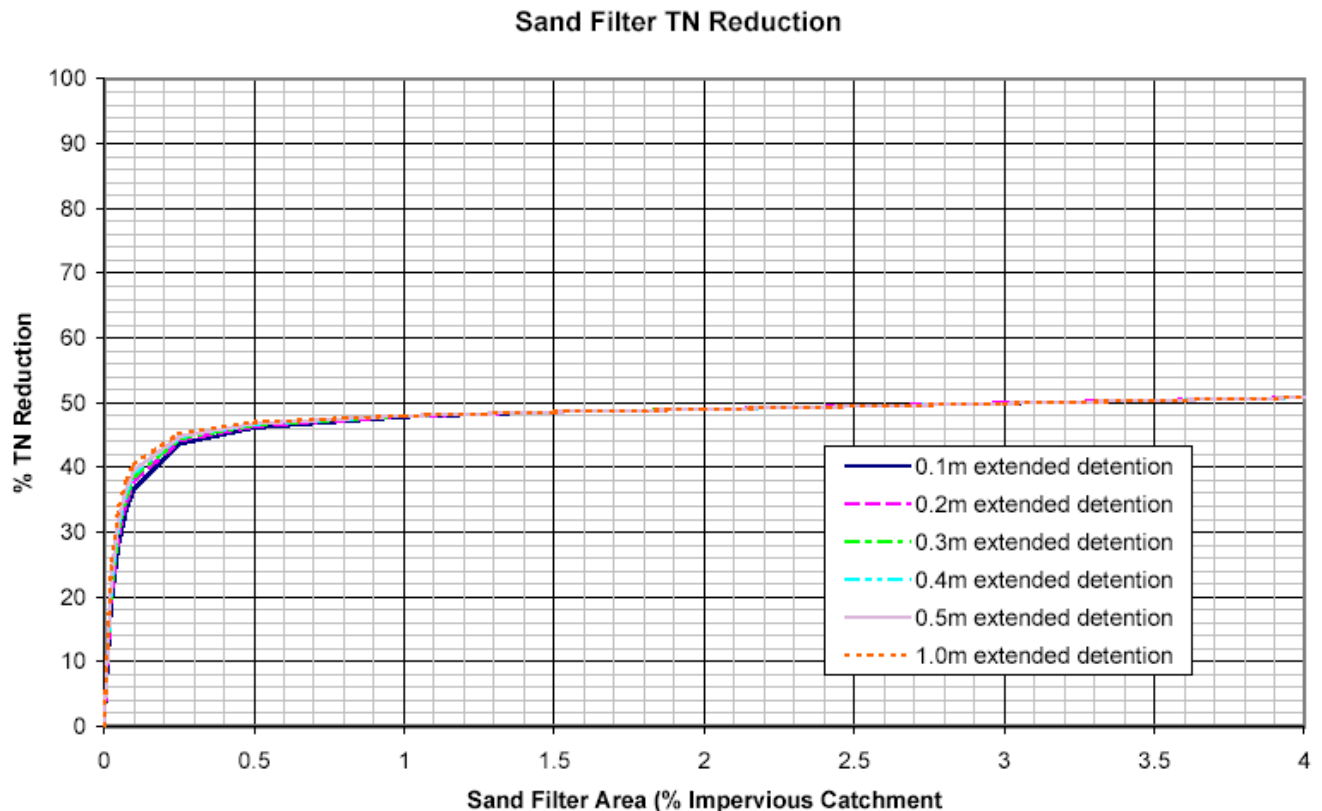

Figure 6.6. Sand Filter TN removal performance

6.3 Design procedure: sand filters

The following sections detail the design steps required for sand filters.

6.3.1 Estimating design flows

Three design flows are required for sand filters:

- Sedimentation chamber design flow – this would normally correspond to the 1 year ARI peak discharge as standard practice for sedimentation basins
- Sand filter design flow – this is the product of the maximum infiltration rate and the surface area of the sand filter, and is used to determine the minimum discharge capacity of the under-drains to allow the filter media to freely drain
- Overflow chamber design flow – this would normally correspond to the minor drainage system (typically 5 or 10-year ARI) to size the weir connecting the sand filter to the overflow chamber. This allows minor floods to be safely conveyed and not increase any flooding risk compared to conventional stormwater systems.

6.3.1.1 Minor and major flood estimation

A range of hydrologic methods can be applied to estimate design flows. With typical catchment areas being relatively small, the Rational Method Design Procedure is considered to be a suitable method for estimating design flows.

6.3.1.2 Maximum infiltration rate

The maximum infiltration rate represents the design flow for the under-drainage system (i.e. the slotted pipes at the base of the filter media). The capacity of the under-drains needs to be greater than the maximum infiltration rate to ensure the filter media drains freely and the pipe doesn't become a 'choke' in the system.

A maximum infiltration rate (Q_{\max}) can be estimated by applying Darcy's equation:

$$Q_{\max} = k \cdot A \cdot \frac{h_{\max} + d}{d}$$

Equation 6.1

where k is the hydraulic conductivity of the soil filter (m/s)

A is the surface area of the sand filter (m²)

h_{\max} is the depth of pondage above the sand filter (m)

d is the depth of the filter media (m)

6.3.2 Hydraulic Structure details

6.3.2.1 Sedimentation Chamber

Inlet into the sand filter is via the sedimentation chamber. The dimension of this chamber should be sized to retain sediment larger than 125 μm for the design flow and to have adequate capacity to retain settled sediment such that the cleanout frequency is once a year or longer. A target sediment capture efficient of 70% is recommended. This is lower than would be recommended for sedimentation basins that do not form part of a sand filter (see Chapter 3 for Sediment Basin design).

The lower capture efficiencies can be supported partly due to the required maintenance regime of the filter media and particle size range in the filter being of a similar order of magnitude as the target sediment size of 125 μm .

An inspection of the filter media should be carried out every 6 months and in particular after significant rainfall events to ensure the sediment and litter loads can be controlled by the sedimentation chamber.

Inspections of the sedimentation chamber should be performed at similar intervals however sediment clean out may only be required once every year. This will vary from site to site and records of inspections should be kept from each inspection (See Section 7.5.1).

It is necessary to check that deposited sediments of the target sediment size or larger are not resuspended during the passage of the design peak discharge for the overflow chamber. A maximum flow velocity of 0.2 m/s is recommended.

The reader is referred to Chapter 3 for guidance on the sizing the sedimentation chamber.

6.3.2.2 Sand Filter Chamber

The filter media in the sand filter chamber consist of two layers, being a drainage layer consisting of gravel size material to encase the perforated under-drains and the sand filtration layer. The surface of the sand filter should be set at the crest height of the weir connecting the sedimentation chamber to the sand filter chamber. This will minimise any scouring of the sand surface as water is conveyed into the sand filter chamber.

6.3.2.2.1 Filter media specifications

A range of particle size ranges can be used for sand filters depending on the likely size of generated sediments. Material with particle size distributions described below has been reported as effective for stormwater treatment (ARC, 2003):

% passing	9.5 mm	100 %
	6.3 mm	95–100 %
	3.17 mm	80–100 %
	1.5 mm	50–85 %
	0.8 mm	25–60 %
	0.5 mm	10–30 %
	0.25 mm	2–10 %

This grading is based on TP10 (ARC, 2003).

Alternatively finer material can be used (such as that below), however, it requires more attention to maintenance to ensure the material maintains its hydraulic conductivity and does not become blocked. Inspections should be carried out every 3–months during the initial year of operation as well as after major storms to check for surface clogging.

% passing	1.4 mm	100 %
	1.0 mm	80 %
	0.7 mm	44 %
	0.5 mm	8.4 %

This grading is based on a Unimin 16/30 FG sand grading.

6.3.2.2.2 Drainage layer specifications

The drainage layer specification can be either coarse sand or fine gravel, such as a 5 mm or 10 mm screenings. Specification of the drainage layer should take into consideration the perforated pipe system, in particular the slot sizes. This layer should be a minimum of 150 mm and preferably 200 mm thick.

DESIGN NOTE – The use of slotted uPVC over the more traditional choice of flexible agricultural pipe (Agriflex) has numerous advantages:

- ▶ Increased structural strength resulting in greater filter media depths without failure.
- ▶ Consistent grades to maintain self cleansing velocities are more easily maintained.
- ▶ Larger drainage slots allow for faster drainage and less risk of blockage thus increasing service life of the filter bed.
- ▶ Higher flow capacities therefore requiring lower numbers of pipes.

6.3.2.3 Overflow Chamber

The overflow chamber conveys excess flow to downstream drainage infrastructure and the overflow weir should be sized to ensure that it has sufficient capacity to convey the design discharge from the upstream drainage system. The overflow weir should be located in the sedimentation chamber.

When water levels in the sedimentation and sand filter chambers exceed the extended detention depth, water overflows into this chamber and is conveyed into the downstream drainage system.

DESIGN NOTE – Water levels in the overflow chamber should ideally be lower than the crest of the overflow weir. Some level of weir submergence is not expected to severely reduce the discharge capacity of the overflow weir. Water levels must remain below ground when operating at the design discharge of the upstream drainage system.

A broad crested weir equation can be used to determine the length of the overflow weir. i.e.

$$Q_{weir} = C_w \cdot L \cdot H^{1.5}$$

Equation 6.2

where

C_w	is the weir coefficient (~1.7)
L	is the length of the weir (m)
H	is the afflux (m)

6.3.3 Size slotted collection pipes

Either flexible perforated pipes (e.g. AG pipe) or slotted uPVC pipes can be used, however care needs to be taken to ensure the slots in the pipes are not so large that sediment can migrate into the pipes from the drainage layer. They should be sized so that the filtration media is freely drained and the collection system does not become a ‘choke’ in the system.

DESIGN NOTE – There are circumstances where it may be desirable to restrict the discharge capacity of the collection system in order to promote longer

detention periods within the sand media. One such circumstance is when depth constraints may require a shallower filtration depth and a larger surface area, leading to a higher than desired maximum infiltration rate.

The water that has passed through the filtration media, is directed into the collection pipes via a 'drainage layer' (typically fine gravel or coarse sand, 2–10 mm diameter), whose purpose is to efficiently convey treated flows into the collection pipes while preventing any of the filtration media from being washed downstream.

DESIGN NOTE – It is considered reasonable for the maximum spacing of the slotted or perforated collection pipes to be 1.5 m (centre to centre) so that the distance water needs to travel through the drainage layer does not hinder drainage of the filtration media. Installing parallel pipes is a means to increase the capacity of the collection pipe system. A pipe diameter of 100 mm is considered to be a maximum size for the collection pipes.

To ensure the slotted or perforated pipes are of adequate size several checks are required:

- Ensure the perforations (slots) are adequate to pass the maximum infiltration rate (or the maximum required outflow)
- Ensure the pipe itself has adequate capacity
- Ensure the drainage layer has sufficient hydraulic conductivity and will not be washed into the perforated pipes.

6.3.3.1 Perforations inflow check

To estimate the capacity of flows through the perforations, orifice flow conditions are assumed and a sharp edged orifice equation can be used.

Firstly the number and size of perforations needs to be determined (typically from manufacturer's specifications) and used to estimate the flow rate into the pipes using a design pressure head of the filtration media depth, plus the ponding depth. Secondly, it is conservative but reasonable to use a blockage factor (e.g. 50% blocked) to account for partial blockage of the perforations by the drainage layer media.

$$Q_{\text{perforation}} = B \cdot C \cdot A_{\text{perforation}} \sqrt{2gh}$$

Equation 6.3

where

B	is the blockage factor (0.5–0.75)
C	is the orifice coefficient (~0.6)
A	is the area of the perforation
h	is depth of water over the collection pipe

The combined discharge capacity of the perforations in the collection pipe should exceed the design discharge of the sand filter unless the specific intention is to increase detention time in the sand filter by limiting the discharge through the collection pipe.

Prevention of clogging of the perforations is essential and a drainage layer consisting of gravel encasing the slotted pipe is recommended. It is good practice to adopt a blockage factor to account for the likelihood of some of the slots being blocked.

6.3.3.2 Perforated pipe capacity

One form of the Colebrook–White equation can be applied to estimate the velocity and hence flow rate in the perforated pipe. The capacity of this pipe needs to exceed the maximum infiltration rate.

$$V = -2(2gDS_f)^{0.5} \times \log [(k/3.7D) + (2.51\nu/D(2gDS_f)^{0.5})]$$

$$V = Q / A$$

Therefore

$$Q = -2(2gDS_f)^{0.5} \times \log [(k/3.7D) + (2.51\nu/D(2gDS_f)^{0.5})] \times A$$

Equation 6.4

Where D = pipe diameter
A = area of the pipe
S_f = pipe slope
k = wall roughness
ν = viscosity
g = gravity constant

6.3.4 Design principles to facilitate maintenance

There are several key decisions during the design process that have significant impact on the ability to perform maintenance of a sand filter. As sand filters do not support vegetation, maintenance is paramount to performance, especially in maintaining the porosity of the surface of the sand filtration media.

Easy access is the most important maintenance consideration during design. This includes both access to the site (e.g. traffic management options) as well as access to the sedimentation and sand filter chambers (as well as less frequent access to the overflow chamber). Regular inspections are also required, particularly following construction and should be conducted following the first several significant rainfall events. This reinforces the requirement for easy access to the site.

Access into the sand filter chamber is particularly important because of the requirement to remove the fine sediments from the surface layer of the sand filter (top 25–50mm) from the entire surface area when accumulated fine sediment forms a ‘crust’. This may require multiple

entry points to the chamber depending in the scale of the filter. If maintenance crews can not access part of the sand filter chamber it will quickly become blocked and perform no water quality improvement function.

If the sedimentation chamber is required to be drained for maintenance purposes (regardless of whether it is designed to drain between storm events. A drainage valve needs to be designed into systems that have no weep holes that can drain this chamber. Having freely drained material significantly reduces the removal and disposal costs from the sedimentation chamber.

The perforated collection pipes at the base of the sand filter are also important maintenance considerations. Provision should be made for flushing (and downstream capture of flushed material) of any sediment build up that occurs in the pipes. This can be achieved with solid pipe returns to the surface for inspection openings (at the upstream end of the pipes) and a temporary filter sock or equivalent placed over the outlet pipe in the overflow chamber to capture flushed sediment.

6.3.5 Design calculation summary

Below is a design calculation summary sheet for the key design elements of sand filters to aid the design process.

Sand Filters

CALCULATION CHECKSHEET

CALCULATION TASK	OUTCOME	CHECK
1 Identify design criteria conveyance flow standard (ARI) treatment flow rate (ARI) pretreatment objective sand filter area sand filter depth maximum ponding depth	year year μm m^2 m mm	<input type="text"/>
2 Catchment characteristics area slope Fraction impervious	m^2 %	<input type="text"/>
3 Estimate design flow rates Time of concentration estimate from flow path length and velocities	minutes	<input type="text"/>
Identify rainfall intensities station used for IFD data 100 year ARI 1 year ARI	mm/hr mm/hr	<input type="text"/>
Design runoff coefficient C_{10} C_{100}		<input type="text"/>
Peak design flows Q_1 Q_{100}	m^3/s m^3/s	<input type="text"/>
3 Sedimentation chamber required surface area length:width ratio length x width depth Inlet weir length particle sizes CHECK SCOUR VELOCITY (depends on particle size) overflow weir capacity CHECK OVERFLOW CAPACITY	m^2 m m m mm $<.51 \text{ m/s}$ m^3/s	<input type="text"/>
4 Slotted collection pipe capacity pipe diameter number of pipes pipe capacity capacity of perforations soil media infiltration capacity CHECK PIPE CAPACITY > SOIL CAPACITY	mm m^3/s m^3/s m^3/s	<input type="text"/>
5 Sand Filter properties Particle size	% Passing % % % % % %	<input type="text"/>

6.4 Checking tools

This section provides a number of checking aids for designers and referral authorities. In addition, advice on construction techniques and lessons learnt from building sand filters are provided.

Checklists are provided for:

- ▶ Design assessments
- ▶ Construction (during and post)
- ▶ Operation and maintenance inspections
- ▶ Asset transfer (following defects period).

6.4.1 Design assessment checklist

The checklist below presents the key design features that should be reviewed when assessing a design of a sand filter. These considerations include configuration, safety, maintenance and operational issues that should be addressed during the design phase.

Where an item results in an “N” when reviewing the design, referral should be made back to the design procedure to determine the impact of the omission or error.

In addition to the checklist, a proposed design should have all necessary permits for its installations. The referral agency should ensure that all relevant permits are in place. These can include permits to clear vegetation, to dredge, create a waterbody, divert flows or disturb fish or platypus habitat.

Land ownership and asset ownership are key considerations prior to construction of a stormwater treatment device. A proposed design should clearly identify the asset owner and who is responsible for its maintenance. The proposed owner should be responsible for performing the asset transfer checklist (see Section 6.4.4).

Sand Filter Design Assessment Checklist				
Sand Filter location:				
Hydraulics	Minor Flood: (m ³ /s)	Major Flood: (m ³ /s)		
Area	Catchment Area (ha):		Sand Filter Area (m ²)	
Treatment			Y	N
Treatment performance verified from curves?				
Inlet zone/hydraulics			Y	N
Station selected for IFD appropriate for location?				
Sediment chamber dimensions sufficient to retain 125um particles?				
Drainage facilities for sediment chamber provided?				
Overall flow conveyance system sufficient for design flood event?				
Velocities at inlet and within sand filter will not cause scour?				
Bypass sufficient for conveyance of design flood event?				
Collection System			Y	N
Slotted pipe capacity > infiltration capacity of filter media (where appropriate) ?				
Maximum spacing of collection pipes <1.5m?				
Drainage layer >150mm?				
Transition layer provided to prevent clogging of drainage layer?				
Filter Basin			Y	N
Maximum ponding depth will not impact on public safety?				
Selected filter media hydraulic conductivity > 10x hydraulic conductivity of surrounding soil?				
Maintenance access provided to base of filter media (where reach to any part of a basin >6m)?				
Protection from gross pollutants provided (for larger systems)?				
Sand media specification included in design?				

6.4.2 Construction advice

This section provides general advice for the construction of sand filters. It is based on observations from construction projects around Australia.

Building phase damage

Protection of filtration media is very important during building phase, uncontrolled building site runoff is likely to cause excessive sedimentation, introduce debris and litter and could cause clogging of the sand media. Upstream measures should be employed to control the quality of building site runoff. If a sand filter is not protected during building phase it is likely to require replacement of the sand filter media. An additional system of installing a geotextile fabric over the surface of the sand filter during the building phase can also protect the sand filter media below. Accumulated sediment and the geotextile fabric can then be removed following most of the upstream building activity has finished.

Traffic

Ensure traffic and deliveries do not access sand filters during construction. Traffic can compact the filter media and cause preferential flow paths, deliveries can block filtration media. Wash down wastes (e.g. concrete) can cause blockage of filtration media. Sand filters should be fenced off during building phase and controls implemented to avoid wash down wastes.

Sediment basin drainage

When a sediment chamber is designed to drain between storms (so that pollutants are stored in a drained state) weeps holes can be used that are protected from blockage. Blockage can be avoided by constructing a protective sleeve (to protect the holes from debris blockage, e.g. 5mm screen) around small holes at the base of the bypass weir. It can also be achieved with a vertical slotted PVC pipe, with protection from impact and an inspection opening at the surface to check for sediment accumulation. The weep holes should be sized so that they only pass small flows (e.g. 10–15mm diameter).

Perforated pipes

Perforated pipes can be either a uPVC pipe with slots cut into the length of it or a flexible ribbed pipe with smaller holes distributed across its surface (an AG pipe). Both can be suitable. uPVC pipes have the advantage of being stiffer with less surface roughness therefore greater flow capacity, however the slots are generally larger than for flexible pipes and this may cause problems with filter or drainage layer particle ingress into the pipe. Stiff PVC pipes however can be cleaned out easily using simple plumbing equipment. Flexible perforated pipes have the disadvantage of roughness (therefore flow capacity) however have smaller holes and are flexible which can make installation easier. Blockages within the flexible pipes can be harder to dislodge with standard plumbing tools.

Inspection openings in perforated pipes

It is good design practice to have inspection openings at the end of the perforated pipes. The pipes should be brought to the surface (with solid pipes) and have a sealed capping. This allows inspection of sediment buildup when required and easy access for maintenance, such as flushing out accumulated sediments. Sediment controls downstream should be used when flushing out sediments from the pipes to prevent sediments reaching downstream waterways.

Clean filter media

It is essential to ensure drainage media is washed prior to placement to remove fines and prevent premature clogging of the system.

6.4.3 Construction checklist

CONSTRUCTION INSPECTION CHECKLIST Sand filters

INSPECTED BY:
DATE:
TIME:
WEATHER:
CONTACT DURING VISIT:

SITE: _____

CONSTRUCTED BY: _____

DURING CONSTRUCTION									
Items inspected	Checked		Satisfactory	Unsatisfactory		Checked		Satisfactory	Unsatisfactory
Preliminary works	Y	N			Structural components	Y	N		
1. Erosion and sediment control plan adopted					14. Location and levels of pits as designed				
2. Traffic control measures					15. Safety protection provided				
3. Location same as plans					16. Pipe joints and connections as designed				
4. Site protection from existing flows					17. Concrete and reinforcement as designed				
Earthworks					18. Inlets appropriately installed				
5. Level bed					19. Pipe joints and connections as designed				
6. Side slopes are stable					20. Concrete and reinforcement as designed				
7. Provision of liner					Filtration system				
8. Perforated pipe installed as designed					21. Inlets appropriately installed				
9. Drainage layer media as designed					22. Provision of liner				
10. Sand media specifications checked					23. Adequate maintenance access				
Sedimentation chamber					24. Inlet and outlet as designed				
11. Adequate maintenance access									
12. Invert level correct									
13. Ability to freely drain (weep holes)									
FINAL INSPECTION									
1. Confirm levels of inlets and outlets					6. Check for uneven settling of sand				
2. Traffic control in place					7. No surface clogging				
3. Confirm structural element sizes					8. Maintenance access provided				
4. Sand filter media as specified					9. Construction generated sediment and debris removed				
5. Sedimentation chamber freely drains									

COMMENTS ON INSPECTION

ACTIONS REQUIRED

1.
2.
3.
4.
5.
6.

6.4.4 Asset transfer checklist

Asset Handover Checklist		
Asset Location:		
Construction by:		
Defects and Liability Period		
Treatment	Y	N
System appears to be working as designed visually?		
No obvious signs of under-performance?		
Maintenance	Y	N
Maintenance plans provided for each asset?		
Inspection and maintenance undertaken as per maintenance plan?		
Inspection and maintenance forms provided?		
Asset inspected for defects?		
Asset Information	Y	N
Design Assessment Checklist provided?		
As constructed plans provided?		
Copies of all required permits (both construction and operational) submitted?		
Proprietary information provided (if applicable)?		
Digital files (eg drawings, survey, models) provided?		
Asset listed on asset register or database?		

6.5 Maintenance requirements

Maintenance of sand filters is primarily concerned with:

- Regular inspections (3–6 monthly) to inspect sedimentation chamber and the sand media surface
- Maintenance of flows to and through the sand filter
- Removal of accumulated sediments and litter and debris removal from the sedimentation chamber
- Checking to ensure the weep holes and overflow weirs are not blocked with debris.

Maintaining the flow through a sand filter involves regular inspection and removal of the top layer of accumulated sediment. Inspections should be conducted after the first few significant rainfall events following installation and then at least every six months following. The

inspections will help to determine the long term cleaning frequency for the sedimentation chamber and the surface of the sand media.

Removing fine sediment from the surface of the sand media can typically be performed with a flat bottomed shovel or vacuum machinery. Tilling below this surface layer can also maintain infiltration rates. Access is required to the complete surface area of the sand filter and this needs to be considered during design.

Sediment accumulation at in the sedimentation chamber also needs to be monitored. Depending on the catchment activities (e.g. building phase) the deposition of sediment can overwhelm the sedimentation chamber and reduce flow capacities.

Similar to other types of practices, debris removal is an ongoing maintenance function. Debris, if not removed, can block inlets or outlets, and can be unsightly if located in a visible location. Inspection and removal of debris should be done regularly, but debris should be removed whenever it is observed on the site.

6.5.1 Operation & maintenance inspection form

The form below should be used whenever an inspection is conducted and kept as a record on the asset condition and quantity of removed pollutants over time.

Sand Filter Maintenance Checklist			
Inspection Frequency:	6 monthly	Date of Visit:	
<i>Location:</i>			
<i>Description:</i>			
<i>Site Visit by:</i>			
Inspection Items	Y	N	Action Required (details)
Litter within filter?			
Scour present within sediment chamber or filter?			
Traffic damage present?			
Evidence of dumping (eg building waste)?			
Clogging of drainage weep holes or outlet?			
Evidence of ponding?			
Damage/vandalism to structures present?			
Surface clogging visible?			
Drainage system inspected?			
Removal of fine sediment required?			
Comments:			

6.6 Sand filter worked example

6.6.1 Worked example introduction

A sand filter system is proposed to treat stormwater runoff from a courtyard/plaza area in Hobart. The site is nested amongst a number of tall buildings and is to be fully paved as a multi-purpose court yard. Stormwater runoff from the surrounding building is to be directed to bioretention planter boxes while runoff from this 2000 m² courtyard will be directed into an underground sand filter. Provision for overflow into the underground drainage infrastructure ensures that the site is not subjected to flood ponding for storm events up to the 100 year average recurrence interval. The existing stormwater drainage infrastructure has the capacity to accommodate the 100 year ARI peak discharge from this relatively small catchment.

Key functions of a sand filter include the following:

- Promote the capture of gross pollutants
- Promote sedimentation of particles larger than 125 µm within the inlet zone for flows up to a 1 year ARI (unattenuated) peak discharge.
- Promote filtration following sedimentation pre-treatment through a sand layer
- Provide for by-pass operation by configuring and designing the by-pass chamber.

The concept design suggests that the required area of the sand filter chamber is 80 m² and the depth of the sand filter is 600 mm. Outflows from the sand filter are conveyed into a stormwater pipe for discharge into existing stormwater infrastructure (legal point of discharge) via a third chamber, an overflow chamber. Flows in excess of a 200 mm extended detention depth would overflow and discharge directly into the underground stormwater pipe and by-pass the sand filter.

6.6.1.1 *Design Objectives*

Design objectives include the following:

- Sand filter to consist of 3 chambers, a sedimentation (and gross pollutant trapping) chamber, a sand filter chamber and an overflow chamber.
- The sedimentation chamber shall be designed to capture particles larger than 125µm for flows up to the peak 1yr ARI design flow with a capture efficiency of 80%. The outlet from the chamber will need to be configured to direct flows up to the 1yr ARI into the sand filter, flows in excess of 1yr ARI will bypass to the overflow chamber.
- The sand filter shall be designed to filter the peak 1yr ARI flow. Perforated sub-soil drainage pipes are to be provided at the base of the sand filter and will need to be sized to ensure the flow can enter the pipes, (check inlet capacity) and to ensure they have adequate flow capacity.
- The overflow chamber shall be designed to capture and convey flows in excess of the 1yr ARI peak flow and up to the 100 year ARI peak discharge.

- Sedimentation chamber shall retain sediment and gross pollutants in a dry state and to have sufficient storage capacity to limit sediment cleanout frequency to once a year.
- Inlet / outlet pipes to be sized to convey the 100yr ARI peak discharge.

6.6.1.2 Site Characteristics

The site characteristics are summarised as follows:-

- Catchment area 2,000m² (80 m x 25 m)
- Land use/surface type Paved courtyard
- Overland flow slope 1.0%
- Soil type clay
- Fraction impervious 0.90

6.6.2 Verifying size for treatment

The nominated area of the sand filter is 80 m².

According to charts in Section 6.2, a sand filter area of 3.5% of the impervious area will be necessary to reduce TSS load by 80%. Smaller areas are required to attain best practice objectives for TP and TN.

With a fraction impervious of 0.9, the impervious area of the courtyard is 1800 m² and the required sand filter area is 63 m² → OK

DESIGN NOTE – The values derived from 6.2 Verifying size for treatment will only be valid if the design criteria for the proposed installation are similar to those used to create the Figures. Site specific modelling using programs such as MUSIC (eWater, 2009) may yield a more accurate result.

6.6.3 Estimating Design Flows

The calculation of the design flow will be undertaken using the Rational Method.

Length of the longest flow path is assumed to consist of overland flowpath (1/2 width of the courtyard = 12.5m) and gutter flow (1/2 perimeter length of the courtyard = 52.5m). Fall across the courtyard is assumed to be 1%.

The travel time of the overland flow path can be estimated using either the Bransby Williams formula for time of concentration or by the overland kinematic wave equation as presented in Australian Rainfall and Runoff (2003).

Each method has advantages and disadvantages. The Kinematic Wave equation is the most accurate method of calculating t_c and is generally suited to most catchments. As the equation requires the designer to solve for t and $I^{0.4}$ simultaneously, an iterative approach must be undertaken (or use a previously prepared relationship table for $I^{0.4}$ for the study area). The Bransby Williams formula is well suited to situations where no actual relationships for t_c have been calculated based on observed data, and it does not require an iterative process to reach a solution making it attractive to designers new to these theories.

Kinematic wave equation	Bransby Williams formula for t_c
$t = \frac{6.94(L \cdot n^*)^{0.6}}{I^{0.4} \cdot S^{0.3}}$	$t_c = \frac{91 L}{A^{0.1} S_e^{0.2}}$
<p>Where: t is the overland travel time (minutes)</p> <p>L is the overland flow path length (m)</p> <p>N* is the surface roughness (concrete or asphalt ~ 0.013)</p> <p>I is the design rainfall intensity (mm/hr)</p> <p>S is the slope</p>	<p>Where: t_c is the time of concentration (minutes)</p> <p>L is the main stream length measured to the catchment divide (km)</p> <p>A is the catchment area (Ha)</p> <p>S_e is the grade of the main stream (m/km)</p>

Equation 6.5 and Equation 6.6

NOTE – For this example, the Bransby Williams formula will be used.

Step 1 – Calculate the time of concentration.

From equation 7.4b –

$$\begin{aligned}
 T_c &= \frac{91 \times 0.065}{0.2^{0.1} \times 10^{0.2}} \\
 &= 5.915 / 1.348 \\
 &= 4.38 \text{ minutes (assume 5 minutes)}
 \end{aligned}$$

Using a time of concentration of 5 minutes, the design rainfall intensities from the IFD chart relevant to the catchment location are –

$$I_1 = 44 \text{ mm/hr} *$$

$$I_{100} = 170 \text{ mm/hr}*$$

* These figures are for the worked example only. The appropriate region and corresponding rainfall intensities must be selected for each individual project.

Step 2 – Calculate design run-off coefficients (using the method outlined in Australian Rainfall and Runoff Book VIII (Engineers Australia, 2003)).

Where – Fraction impervious (f) = 0.9

Rainfall intensity ($^{10}I_1$) = 28.6mm/hr (from the relevant IFD chart)

Calculate $C^{1_{10}}$ (pervious run-off coefficient)

$$C^{1_{10}} = 0.1 + 0.0133 (^{10}I_1 - 25) = 0.15$$

Calculate C_{10} (10 year ARI run-off coefficient)

$$C_{10} = 0.9f + C^{1_{10}} (1-f)$$

$$C_{10} = 0.82$$

Step 3 – Convert C_{10} to values for C_1 and C_{100}

Where – $C_y = F_y \times C_{10}$

From Table 1.6 in Australian Rainfall and Runoff – Book VII;

$$C_1 = 0.8 \times C_{10} = 0.66$$

$$C_{100} = 1.2 \times C_{10} = 0.98$$

Step 4 – Calculate peak design flow (calculated using the Rational Method).

$$Q = \frac{CIA}{360}$$

Where – C is the runoff coefficient (C_1 and C_{100})

I is the design rainfall intensity mm/hr (I_1 and I_{100})

A is the catchment area (Ha)

$$Q_1 = 0.016 \text{ m}^3/\text{s} \text{ (16 L/s)}$$

$$Q_{100} = 0.093 \text{ m}^3/\text{s} \text{ (93 L/s)}$$

Maximum infiltration rate

The maximum infiltration rate (Q_{\max}) through the sand filter is computed using Equation 6.1, i.e.

$$Q_{\max} = k \cdot A \cdot \frac{h_{\max} + d}{d} = 0.084 \text{ m}^3/\text{s}$$

where k is the hydraulic conductivity of sand = 1×10^{-3} m/s (Engineers Australia, 2003, Ch. 9)

A is the surface area of the sand filter = 63 m²

h_{\max} is the depth of pondage above the sand filter = 0.2 m

d is the depth of the sand filter = 0.6 m

Design Flows	$Q_1 = 0.016 \text{ m}^3/\text{s}; Q_{100} = 0.093 \text{ m}^3/\text{s};$
	Maximum Infiltration Rate = 0.084 m ³ /s

6.6.4 Hydraulic Structures

6.6.4.1 *Sizing of Sedimentation Basin*

The sedimentation chamber is to be sized to remove the 125µm particles for the peak 1-year flow.

Pollutant removal is estimated using Equation 3.3 (see Chapter 3):

$$R = 1 - \left[1 + \frac{1}{n} \cdot \frac{v_s}{Q/A} \cdot \frac{(d_e + d_p)}{(d_e + d^*)} \right]^{-n}$$

A notional aspect ratio of 1 (w) to 2 (L) is adopted. From Equation 3.3, the hydraulic efficiency (λ) is 0.3. The turbulence factor (n) is computed from Equation 3.2 to be 1.4.

Hydraulic efficiency (λ) = 0.3

Turbulence factor (n) = 1.4

The proposed extended detention depth of the basin is 0.2m (as outlined in Section 6.6.1) and a notional permanent pool depth of 0.6 m (equal to the depth of the sand filter) has been adopted, i.e.

$$d_p = 0.6 \text{ m}$$

$$d^* = 0.6 \text{ m}$$

$$d_e = 0.20\text{m}$$

$$V_s = 0.011 \text{ m/s for } 125\mu\text{m particles}$$

$$Q = \text{Design flow rate} = 0.016 \text{ m}^3/\text{s}$$

The required sedimentation basin area to achieve target sediment (125 µm) capture efficiency of 70% is 2.8 m². With a W to L ratio of 1:2, the notional dimensions of the basin are 1.4 m x 2.0 m. This size is validated against the curves presented in Figure 3.2 (see Chapter 3).

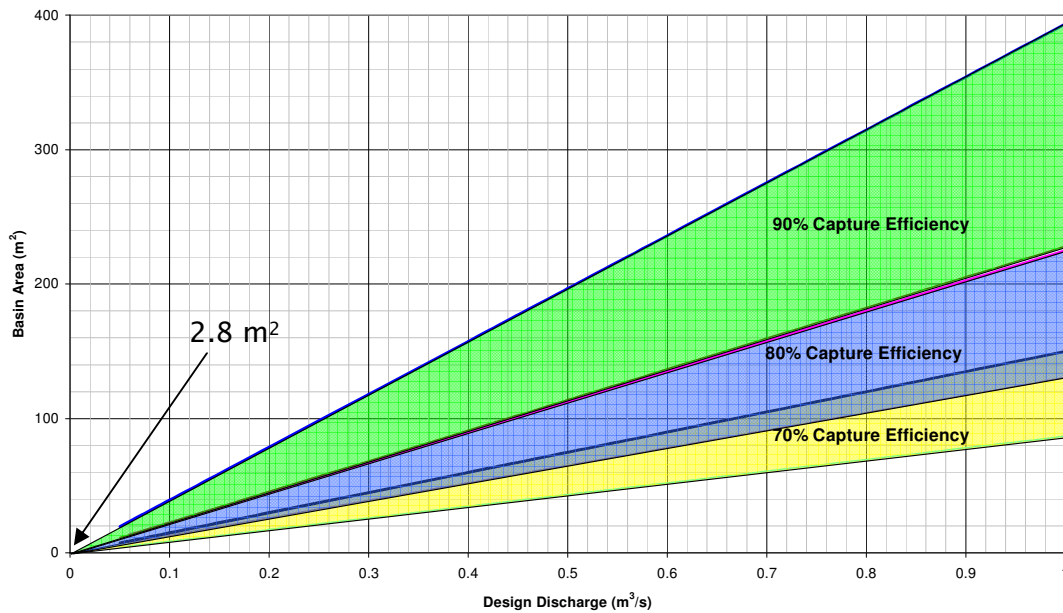

The available sediment storage is $2.8 \times 0.6 = 1.68 \text{ m}^3$. Cleanout is to be scheduled when the storage is half full. Using a sediment discharge rate of $1.6 \text{ m}^3/\text{Ha}/\text{yr}$, the clean out frequency is estimated to be:

$$\text{Frequency of basin desilting} = \frac{0.5 \times 1.68}{0.7 \times 1.6 \times 0.2} = 3.75 \text{ years} > 1 \text{ year} \rightarrow \text{OK}$$

During the 100 year ARI storm, peak discharge through the sedimentation chamber will be $0.093 \text{ m}^3/\text{s}$ with flow depth of 0.8 m . It is necessary to check that flow velocity does not re-suspend deposited sediment of $125 \mu\text{m}$ or larger ($\leq 0.2 \text{ m/s}$).

The mean velocity in the chamber is calculated as follows:

$$V_{100} = 0.093 / (1.4 \times 0.8) = 0.083 \text{ m/s} \rightarrow \text{OK}$$

The length of the sedimentation chamber is 2.0 m . Provide slots of total length of 1.2 m connecting it to the sand filter chamber. The connection discharge capacity should be greater than the 1 year ARI peak flow ($0.016 \text{ m}^3/\text{s}$) and can be calculated using the weir equation as follows:

$$Q_{\text{connection}} = C_w L H^{1.5}$$

where C_w is the weir coefficient (assume = 1.4 for a broad crested weir)
 H is the afflux = 0.2 m (extended detention in sedimentation chamber)
 L is the length of the weir

The discharge capacity calculated from the above equation is $0.15 \text{ m}^3/\text{s} \gg 1 \text{ year ARI discharge of } 0.016 \text{ m}^3/\text{s}$.

Sedimentation Chamber = 2.8 m^2
 Width = 1.4 m ; Length = 2.0 m
 Total weir length of connection to sand filter chamber = 1.2 m

Depth of chamber from weir connection to sand filter = 0.6 m

Depth of Extended Detention (d_e) = 0.2m

6.6.4.2 Sand Filter Chamber

6.6.4.2.1 Dimensions

With the length of sedimentation chamber being 2.0 m, the dimension of the sand filter chamber is determined to be 2.0 m x 32.0 m, giving an area of 64 m².

Sand filter chamber dimension: 2.0 m x 32.0 m

6.6.4.2.2 Media specifications

Sand filter layer to consist of sand/coarse sand material with a typical particle size distribution is provided below:

% passing	1.4 mm	100 %
	1.0 mm	80 %
	0.7 mm	44 %
	0.5 mm	8.4 %

This grading is based on a Unimin 16/30 FG sand grading.

The drainage layer is to consist of fine gravel, of 5 mm screenings.

No impervious liner is necessary as in situ soil is clay.

Filter layer is to be 600mm deep and consist of sand with 80% greater than 1 mm diameter

Drainage layer to be 200mm deep and consist of 5 mm gravel

6.6.4.3 Overflow Chamber

The width of the sedimentation chamber has been selected to be 1.4 m. A weir set at 0.8 m from the base of the sedimentation chamber (or 0.2 m above the surface of the sand filter) of 1.4 m length needs to convey flows up to the 100 year ARI peak discharging into the overflow chamber.

Calculate the afflux resulting from conveying the 100 year ARI peak discharge through a 1.4 m length weir, i.e.

$$H = \left(\frac{Q_{weir}}{C_w \cdot L} \right)^{0.667} = 0.17 \text{ m, say } 0.2 \text{ m}$$

where Q_{weir} is the design discharge = 0.093 m³/s

C_w is the weir coefficient (~1.7)

L is the length of the weir (m)

H is the afflux (m)

With an afflux of 0.2, the discharge capacity of the overflow weir is $0.21 \text{ m}^3/\text{s} > 100 \text{ year ARI peak flow of } 0.093 \text{ m}^3/\text{s}$.

Crest of overflow weir = 0.2 m above surface of sand filter
 Length of overflow weir = 1.4m, 100 year ARI Afflux = 0.2 m
 Roof of facility to be at least 0.4 m above sand filter surface

6.6.5 Size slotted collection pipes

6.6.5.1 *Perforations inflow check*

The following are the characteristics of the selected slotted pipe

- Clear openings = $2100 \text{ mm}^2/\text{m}$
- Slot width = 1.5mm
- Slot length = 7.5mm
- No. rows = 6
- Diameter of pipe = 100mm

For a pipe length of 1.0 m, the total number of slots = $2100/(1.5 \times 7.5) = 187$.

Discharge capacity of each slot can be calculated using the orifice flow equation (Equation 6.3), i.e.

$$Q_{\text{perforation}} = C \cdot A_{\text{perforation}} \sqrt{2gh} = 2.67 \times 10^{-5} \text{ m}^3/\text{s}$$

where h is the head above the slotted pipe, calculated to be 0.80 m.

C is the orifice coefficient (~0.6)

The inflow capacity of the slotted pipe is thus $2.67 \times 10^{-5} \times 187 = 5 \times 10^{-3} \text{ m}^3/\text{s}/\text{m-length}$

Adopt a blockage factor of 0.5 gives the inlet capacity of each slotted pipe to be $2.5 \times 10^{-3} \text{ m}^3/\text{s}/\text{m-length}$.

Maximum infiltration rate is $0.083 \text{ m}^3/\text{s}$. The minimum length of slotted pipe required is

$$L_{\text{slotted pipe}} = 0.083/2.5 \times 10^{-3} = 33.2 \text{ m} = 17 \text{ lengths of } 2.0 \text{ m at } 1.5 \text{ m spacing.}$$

17 slotted pipes (2.0 m length) at 1.5 m spacing required

6.6.5.2 Slotted pipe capacity

The diameter of the slotted pipe is 100 mm. The discharge capacity of the collection pipe is calculated using an Colebrook–White equation (Equation 6.4), i.e.

$$Q = -2(2gDS_f)^{0.5} \times \log \left[\frac{k}{3.7D} + \frac{2.51 \nu / D}{(2gDS_f)^{0.5}} \right] \times A$$

Where D = pipe diameter

A = area of the pipe

S_f = pipe slope

k = wall roughness

ν = viscosity

g = gravity constant

Total discharge capacity (17 pipes) = 0.323 m³/s > maximum infiltration rate of 0.083 m³/s
→ OK

Combined slotted pipe discharge capacity = 0.323 m³/s and exceeds the maximum infiltration rate.

6.6.6 Design Calculation Summary

Sand Filters

CALCULATION CHECKS

CALCULATION TASK	OUTCOME	CHECK
1 Identify design criteria		
conveyance flow standard (ARI)	100 year	
treatment flow rate (ARI)	1 year	
pretreatment objective	125 μm	
sand filter area	6 m^2	
sand filter depth	0.6 m	
maximum ponding depth	200 mm	<input checked="" type="checkbox"/>
2 Catchment characteristics		
area	2000 m^2	
slope	1 %	
Fraction impervious	0.9	<input checked="" type="checkbox"/>
3 Estimate design flow rates		
Time of concentration		
estimate from flow path length and velocities	5 minutes	<input checked="" type="checkbox"/>
Identify rainfall intensities		
station used for IFD data	Hobart	
100 year ARI	170 mm/hr	
1 year ARI	44 mm/hr	<input checked="" type="checkbox"/>
Peak design flows		
Q_1	0.016 m^3/s	
Q_{100}	0.09 m^3/s	<input checked="" type="checkbox"/>
4 Sedimentation chamber		
required surface area	2 m^2	
length:width ratio	1:2	
length x width	2 x 1.4 m	
depth	0.6 m	
Inlet weir length	1.2 m	
particle sizes	1.0 mm	
CHECK SCOUR VELOCITY (depends on particle size)	0.08 < 0.2 m/s	
overflow weir capacity	0.54 m^3/s	
CHECK OVERFLOW CAPACITY	YES	<input checked="" type="checkbox"/>
5 Slotted collection pipe capacity		
pipe diameter	150 mm	
number of pipes	17	
combined pipe capacity	0.323 m^3/s	
capacity of perforations	0.05 m^3/s	
soil media infiltration capacity	0.083 m^3/s	
CHECK PIPE CAPACITY > SOIL CAPACITY	YES	<input checked="" type="checkbox"/>
6 Sand Filter properties		
Percent Passing	1.40 100 %	
Unimin 16/30 FG	1.18 96 %	
	1.00 80 %	
	0.85 63 %	
	0.71 44 %	
	0.60 24 %	
	0.50 8 %	
	0.425 1 %	<input checked="" type="checkbox"/>

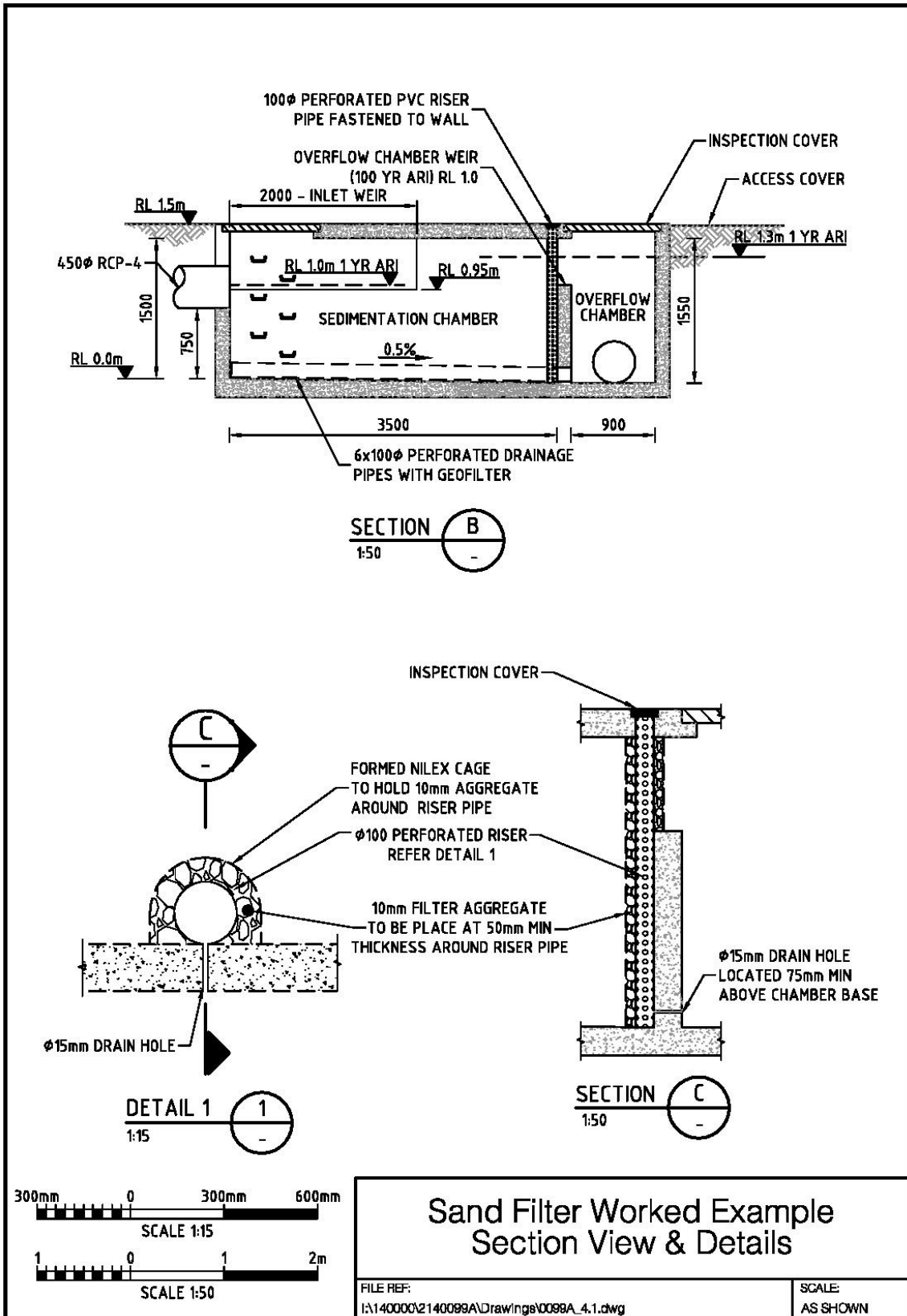

6.7 References

Auckland Regional Council (ARC), 2003, *Stormwater management devices: Design guidelines manual*, May, New Zealand

Engineers Australia, 2006, *Australian Runoff Quality Australian Runoff Quality: A guide to Water Sensitive Urban Design*, Editor-in-Chief, Wong, T.H.F.

eWater, 2009, Model for Urban Stormwater Improvement Conceptualisation (MUSIC) User Manual, Version 4.0, September.

Institution of Engineers Australia, 1997, *Australian Rainfall and Runoff - A guide to flood estimation*, Editor in Chief - Pilgram, D.H.